

CURRENT TRANSFORMER

Model 139

Window Diameter 6.50"

Application:
Relaying and Metering

Frequency:
50 - 400 Hz

Insulation Level:
600 Volts, 10 kv BIL full wave



E228202

- Terminals are brass screws No. 10 - 32
- with one 6flat washer, lockwasher and regular nut.
- □ Multi ratios available upon request
- Order mounting bracket kit CR-CL separately.
- □ Approximate weight: 40 lbs.

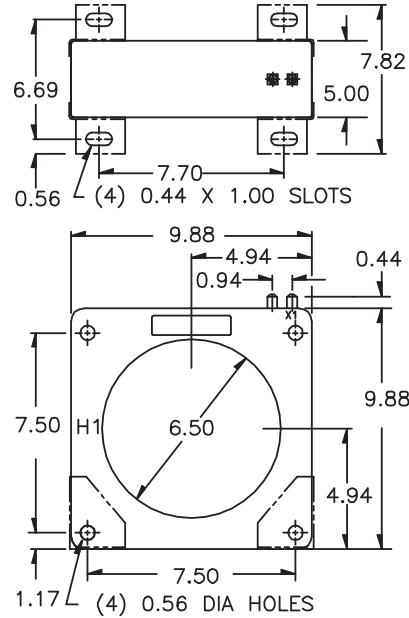
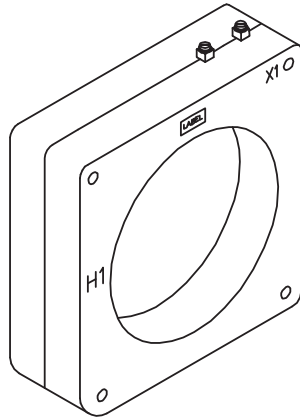

EXCITATION CURVE

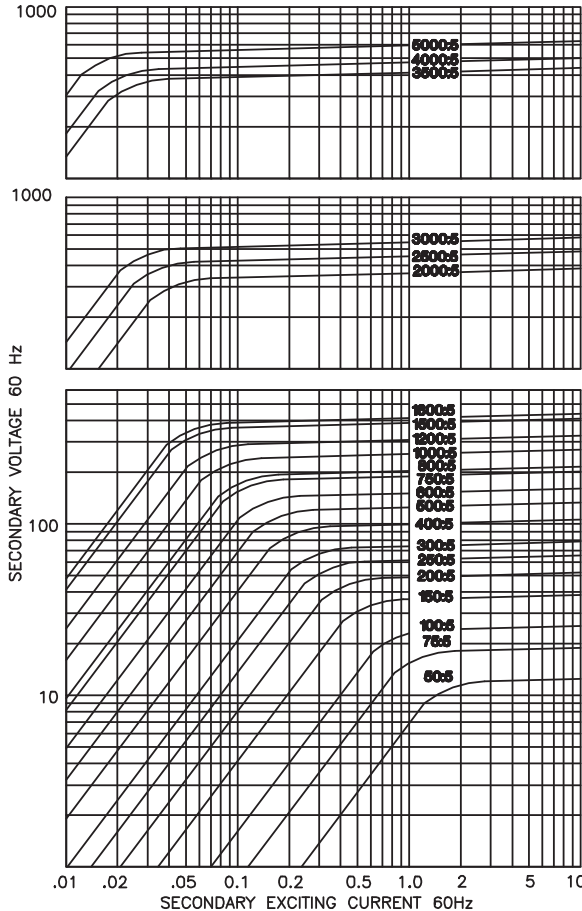

CATALOG NUMBER	CURRENT RATIO	RELAY CLASS	ANSI METERING CLASS AT 60 Hz					SECONDARY WINDING RESISTANCE (OHMS @ 75 °C)	CONTINUOUS THERMAL RATING FACTOR	
			B0.1	B0.2	B0.5	B0.9	B1.8		@30°C	@55°C
139-500	50:5	C10	4.8	-	-	-	-	0.018	2.0	2.0
139-750	75:5	C10	2.4	4.8	-	-	-	0.027	2.0	2.0
139-101	100:5	C20	1.2	2.4	4.8	4.8	-	0.036	2.0	2.0
139-151	150:5	C20	0.6	1.2	2.4	2.4	4.8	0.053	2.0	2.0
139-201	200:5	C20	0.6	0.6	1.2	2.4	2.4	0.071	2.0	2.0
139-251	250:5	C50	0.3	0.6	1.2	1.2	2.4	0.089	2.0	2.0
139-301	300:5	C50	0.3	0.3	0.6	1.2	1.2	0.107	2.0	2.0
139-401	400:5	C50	0.3	0.3	0.3	0.6	1.2	0.142	2.0	2.0
139-501	500:5	C100	0.3	0.3	0.3	0.3	0.6	0.178	2.0	2.0
139-601	600:5	C100	0.3	0.3	0.3	0.3	0.6	0.214	2.0	2.0
139-751	750:5	C100	0.3	0.3	0.3	0.3	0.3	0.267	2.0	2.0
139-801	800:5	C100	0.3	0.3	0.3	0.3	0.3	0.285	2.0	2.0
139-102	1000:5	C200	0.3	0.3	0.3	0.3	0.3	0.563	1.5	1.5
139-122	1200:5	C200	0.3	0.3	0.3	0.3	0.3	0.676	1.5	1.33
139-152	1500:5	C200	0.3	0.3	0.3	0.3	0.3	0.845	1.5	1.0
139-162	1600:5	C200	0.3	0.3	0.3	0.3	0.3	0.901	1.5	1.0
139-202	2000:5	C200	0.3	0.3	0.3	0.3	0.3	0.823	1.5	1.0
139-252	2500:5	C200	0.3	0.3	0.3	0.3	0.3	1.029	1.5	1.0
139-302	3000:5	C400	0.3	0.3	0.3	0.3	0.3	1.235	1.33	1.0
139-352	3500:5	C200	0.3	0.3	0.3	0.3	0.3	1.352	1.0	1.0
139-402	4000:5	C200	0.3	0.3	0.3	0.3	0.3	1.545	1.0	0.8
139-502	5000:5	C400	0.3	0.3	0.3	0.3	0.3	3.025	1.0	0.8

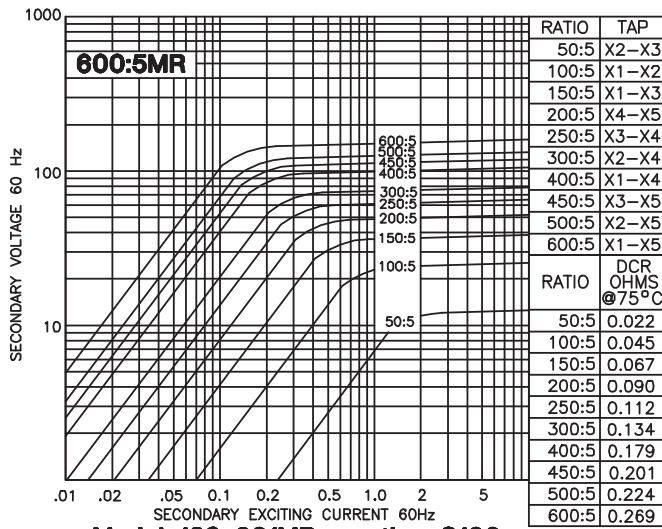

Model 139-601MR - rating C100
TRF= 2.0 @ 30°C, 2.0 @ 55°C amb.

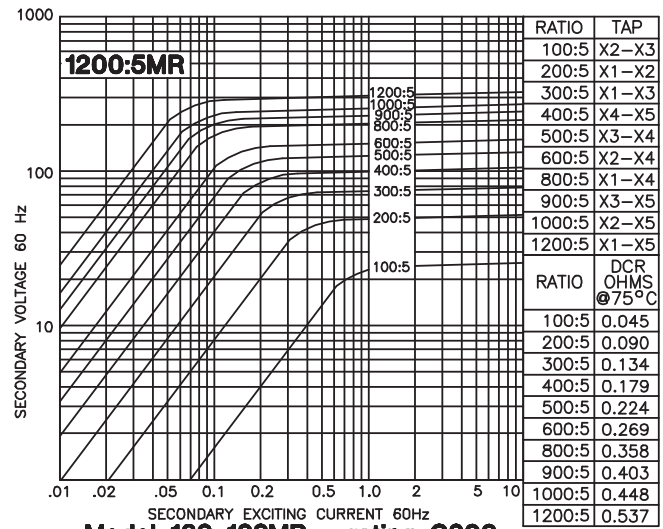

Model 139-122MR - rating C200
TRF= 1.5 @ 30°C, 1.33 @ 55°C amb.

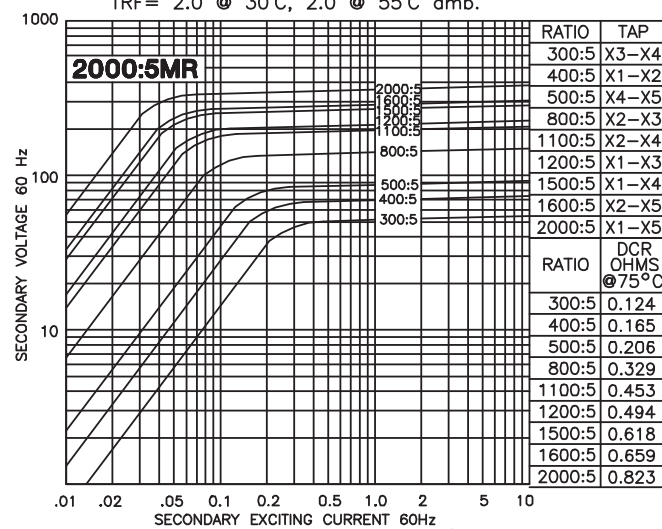

Model 139-202MR - rating C200
TRF= 1.5 @ 30°C, 1.33 @ 55°C amb.

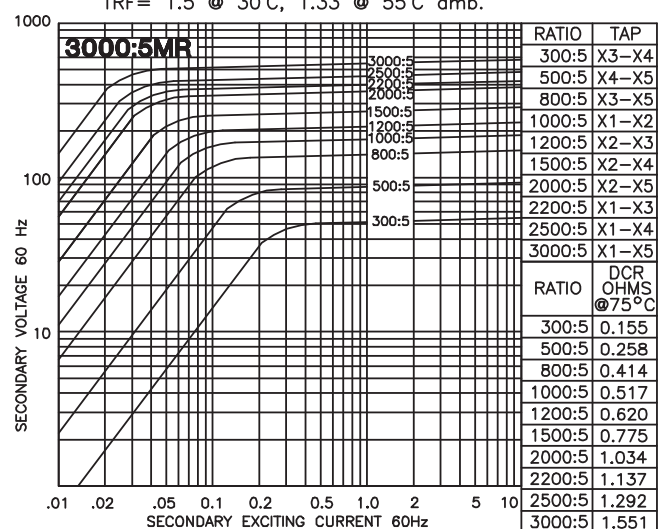

Model 139-302MR - rating C400
TRF= 1.33 @ 30°C, 1.0 @ 55°C amb.

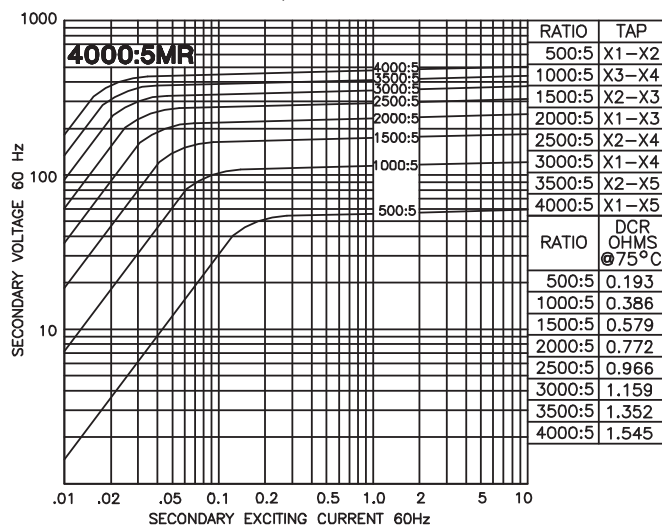

Model 139-402MR - rating C200
TRF= 1.0 @ 30°C, 0.8 @ 55°C amb.

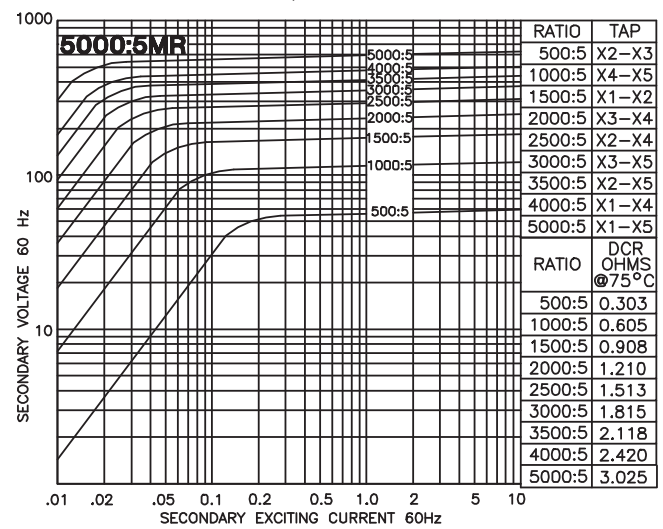

Model 139-502MR - rating C400
TRF= 1.0 @ 30°C, 0.8 @ 55°C amb.