

3 PHASE VOLTAGE TRANSFORMER

Model 3VTN460

For line to neutral connection

Frequency:
60 Hz

Standard Secondary Voltage:
120 Volts Line-to-neutral

Insulation Level:
600 Volts, 10 kv BIL full wave

Accuracy Class: (Per Phase)
0.6 W, 1.2 X at 60 Hz.

Thermal Rating: (Per Phase)
150 VA at 30°C amb.
100 VA at 55°C amb.



E228202

- The model 3VTN460 is an assembly of three transformers in one case.
- The primary and secondary terminals are No. 8-32 screws into 1/2" deep brass inserts and fitted with one lockwasher and flatwasher.
- The core and coil assembly is encased in a thermoplastic shell and filled with resin.
- These transformers are designed for operation line to neutral.
- Spacing between live parts per U.L. 1558.
- Primary fuses are current limiting, 200kA interrupting capacity, incorporating a rejection feature, typically (class CC) KTK-R type.
- It is desirable to use a 1.6 amp BBS type or equal fuse in the secondary to protect the transformer.
- The transformer has a clear plastic terminal cover.
- Only ground N/n terminals if source is 3 phase, 4 wire effectively grounded.
- See page 3 of this section for a circle diagram for the estimation of the errors for other than rated burdens. See page 8 in this section for a description of its use.
- Approximate weight: 24 lbs.

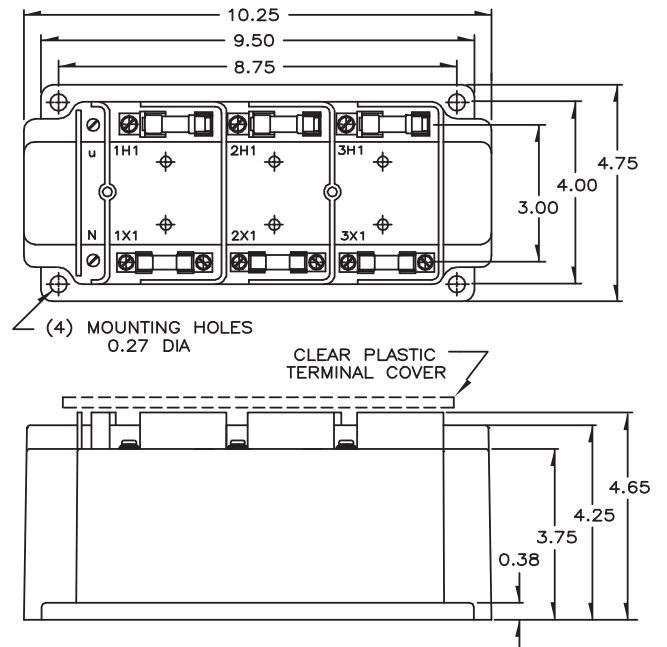
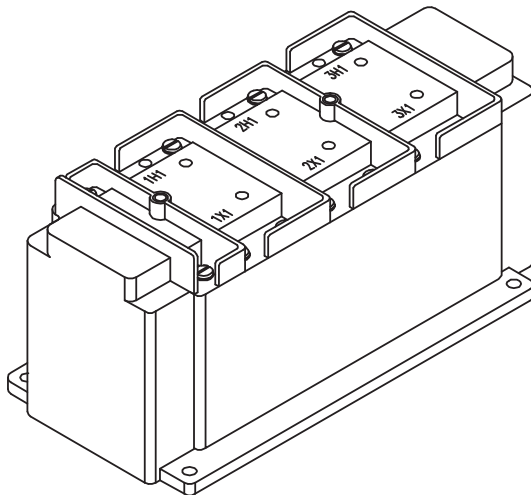

CATALOG NUMBER		LINE TO NEUTRAL VOLTAGE RATING	TURNS RATIO	REC. PRIMARY FUSE RATING
PRIMARY FUSES ONLY	PRIMARY AND SECONDARY FUSES			
3VTN460-069F*	3VTN460-069FF*	69.3:120	0.58:1	5.0
3VTN460-120F*	3VTN460-120FF*	120:120	1:1	4.0
3VTN460-240F*	3VTN460-240FF*	240:120	2:1	2.0
3VTN460-277F*	3VTN460-277FF*	277:120	2.31:1	2.0
3VTN460-300F*	3VTN460-300FF*	300:120	2.5:1	1.5
3VTN460-346F*	3VTN460-346FF*	346:120	2.88:1	1.5

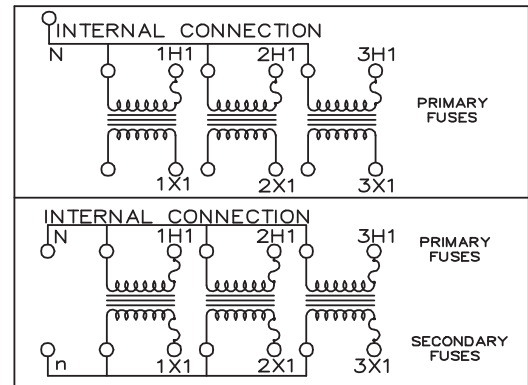

CONNECTION DIAGRAMS

* FUSE ORDERING
INSERT F AFTER PRIMARY VOLTAGE RATING FOR PRIMARY FUSES,
INSERT FF AFTER PRIMARY VOLTAGE RATING FOR PRIMARY AND
SECONDARY FUSES.