



MOTORTRONICS™

Solid State AC Motor Control

TE-RTD12 Relay

USER MANUAL



Table of contents

1	About the Motortronics TE-RTD12 Relay Device	2
1.1	General	2
1.2	Dimensions and Mounting	3
1.3	General Wiring Diagram	4
1.3.1	Wire Size and Tightning Torque	5
1.3.2	CT Connection: Core Balance Connection.....	5
1.3.3	Ct Connection: Summing Method.....	6
1.4	Keypad.....	7
1.4.1	Layout and Description	7
1.4.2	Navigation	8
1.5	Quick Start-Up	9
2	Parameters	11
2.1	Parameters Overview	11-17
2.2	Parameters Detailed Explanation	18
2.2.1	RTD Settings.....	18-27
2.2.2	Digital Inputs	28
2.2.3	Analog Inputs	29
2.2.4	Analog Output.....	32
2.2.5	Device Setting.....	333
2.2.6	Differential CTs	33
2.2.7	Relay Settings.....	34
2.2.8	Communication	35
2.2.9	Real Time Clock.....	36
2.2.10	Display	37-38
2.2.11	Relay Configuration	38-39
2.2.12	System Settings.....	39
2.2.13	Device Information.....	40
3	Fault History and Event Records	41
3.1	Fault History.....	41
3.2	Fault Code Table	42
3.3	Event Records	43
4	MODBUS RTU Communication	44
4.1	Serial Connection / Wiring.....	44
4.2	Serial Communication Settings	45
4.3	MODBUS RTU Message Structure	45-48
4.4	Main Registers.....	49-54
4.5	Monitor Registers.....	55
	APPENDIX A: TECHNICAL SPECIFICATIONS	56
	WARRANTY INFORMATION	57

1 About the Motortronics TE-RTD12 Relay Device

1.1 General

The **TE-RTD12 Relay** device adds advanced RTD (Resistor Temperature Detector) and differential current monitoring capability to your new or existing motor system. The TE-RTD12 Relay device offers 12 built-in RTD inputs, 3 programmable output relays (5A), 2 isolated analog inputs (4-20mA), 1 isolated analog output (4-20mA), 3 isolated digital inputs and differential current feedback monitoring.

Additionally, an RS485 (2 wire) communication port is available for use with a master device (PLC / SCADA / Operator Interface) for the purpose of programming and/or monitoring.

Programmable relay outputs are provided that can be configured for a system function or for use as a global Alarm or Trip based on temperature readout, which can be entered in °C or °F.

A built-in event recorder stores fault history of past events with data points including Alarm / Trip Code, Current / Temperature value, Analog input value and Date / Time Stamp.

The **TE-RTD12 Relay** device can be mounted on a back panel using the mounting bracket or DIN-Rail mount.

NOTES -

1.2 Dimensions and Mounting

Dimensions:

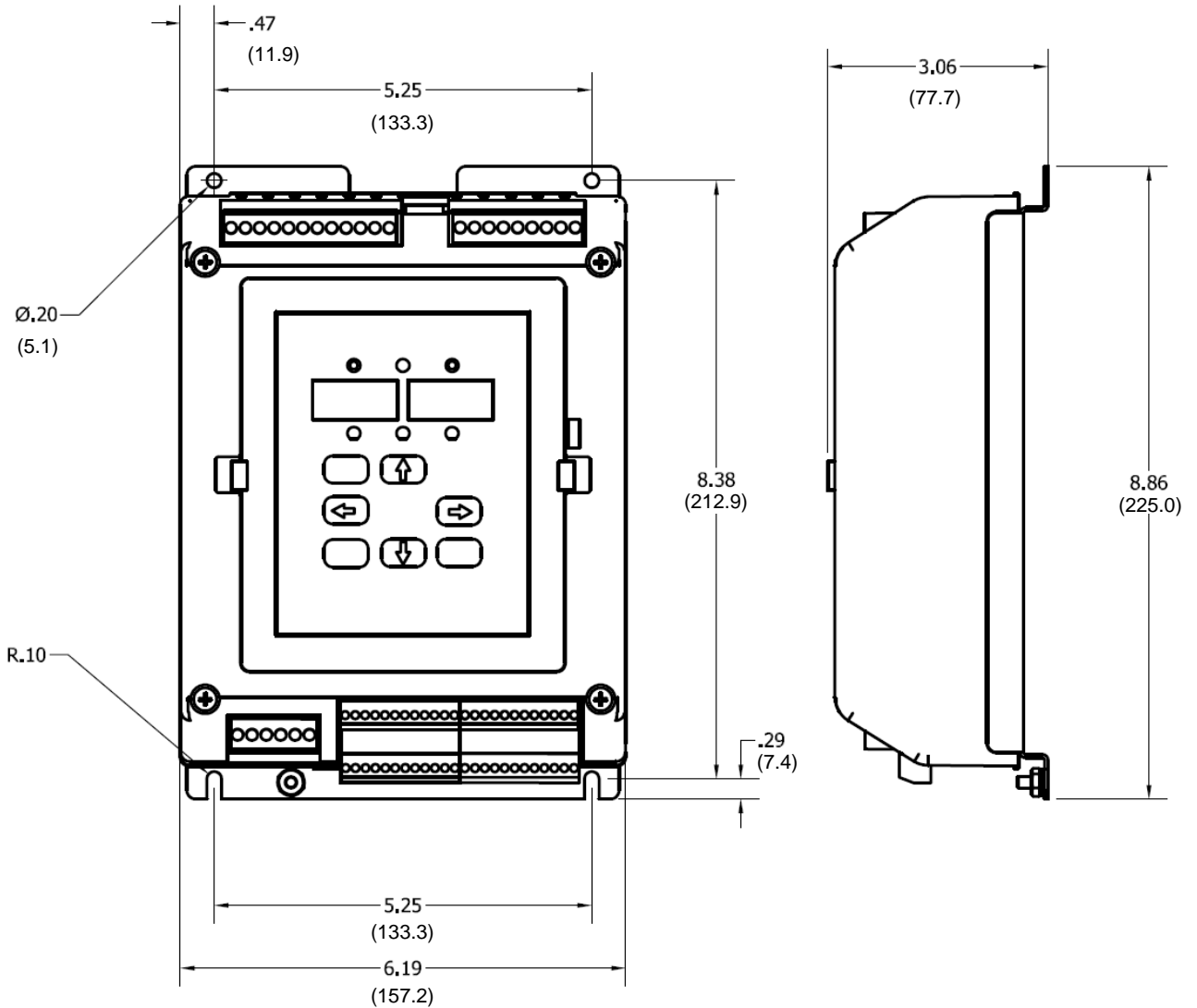

8.86" x 6.19" x 3.06" (H x W x D)

225mm x 157.2mm x 77.7mm (H x W x D) (mm)

Mounting

Use the designated mounting holes to mount the TE-RTD12 in the designated area of your system.

1.3 General Wiring Diagram

The following figure shows the general wiring diagram for the TE-RTD12 Relay Device. The terminal blocks are removable (pluggable) for ease of wiring.

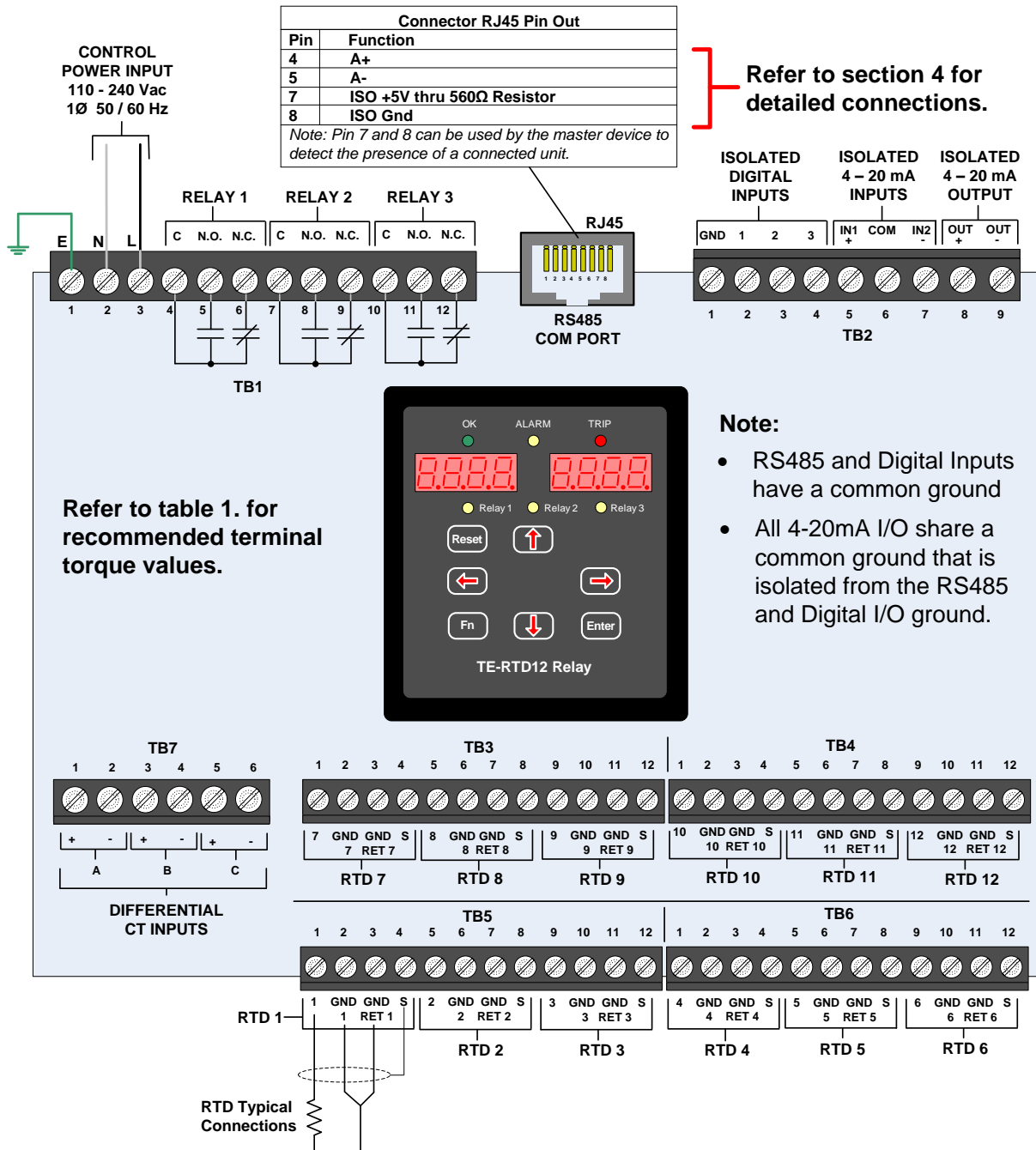

TE-RTD12 Relay Device General Wiring Diagram



CAUTION: DO NOT CONNECT INPUT POWER TO TB2, TB3, TB4, TB5, TB6 or TB7 ONLY CONNECT INPUT POWER TO TB1 TERMINAL N AND L (110 - 240Vac)

1.3.1 Wire Size and Tightening Torque

Connector	Wire Size AWG	Tightening Torque Recommended in-Lb	Tightening Torque Maximum in-Lb
TB1, TB2, TB7	30 - 12	4.42	4.42
TB3, TB4	30 - 14	2.21	2.21
TB5, TB6	30 - 14	1.77	2.21

Table 1

1.3.2 CT Connection: Core Balance Connection

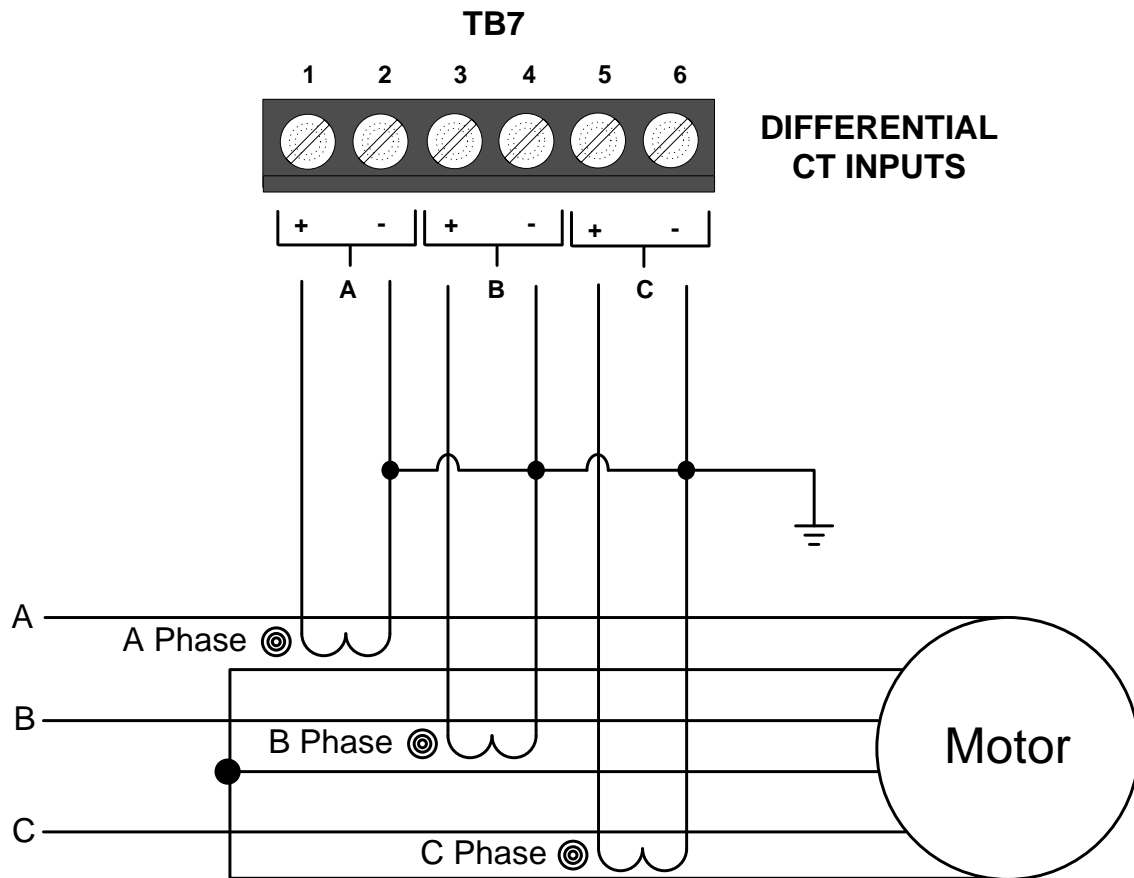

1.3.3 CT Connection: Summing Method

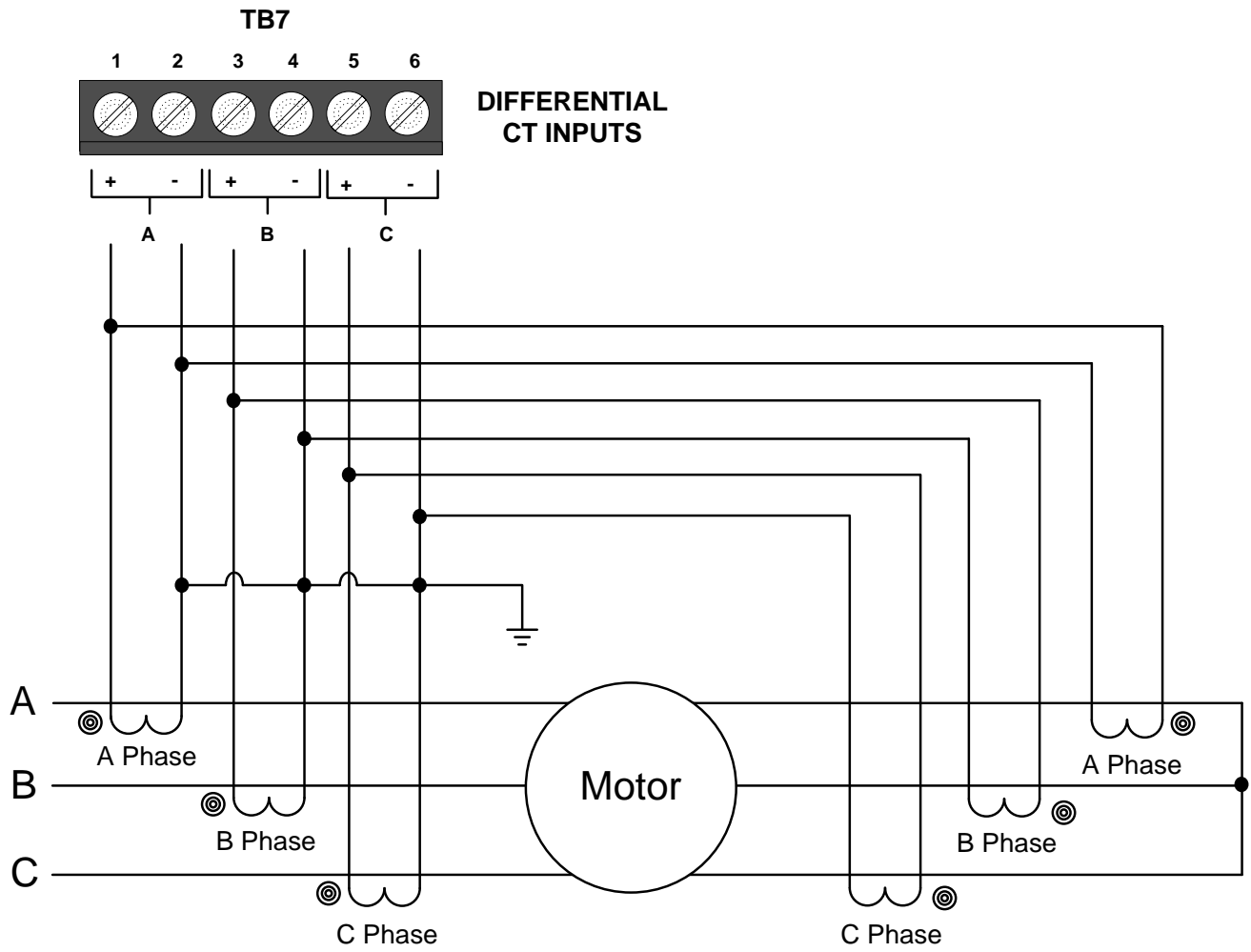

1.4 Keypad

1.4.1 Layout and Description

The Keypad for the **TE-RDT12 Relay** incorporates an 8 digit LED display, a membrane keypad for programming, data entry and data retrieval. There are also 6 LED status indicators.



TE- RTD12 Keypad

Keypad Description		
Keys	Reset	Resets the device after the conditions that cause an ALARM or TRIP have been cleared
	Fn	Enter program mode (view event log)
	Up and Down Arrows	Monitor Navigation / increase or decrease value
	Right and Left Arrows	Each key press shifts the active (flashing) digit to the right or left by one position, allowing you to change higher values of functions without waiting to Auto-step through large numbers.
	Enter	Read and save parameter changes
Display	8888 8888	Two 4-digit 7-segment LED displays
LED	OK (Green)	ON: Indicates that there are no Alarms or Trips. (Yellow and Red LED's are OFF)
	ALARM (Yellow)	ON: An ALARM is active
	TRIP (Red)	ON: A TRIP has occurred
	Relay 1 (Yellow)	ON: Relay is activated
	Relay 2 (Yellow)	
	Relay 3 (Yellow)	

Table 2

1.4.2 Navigation

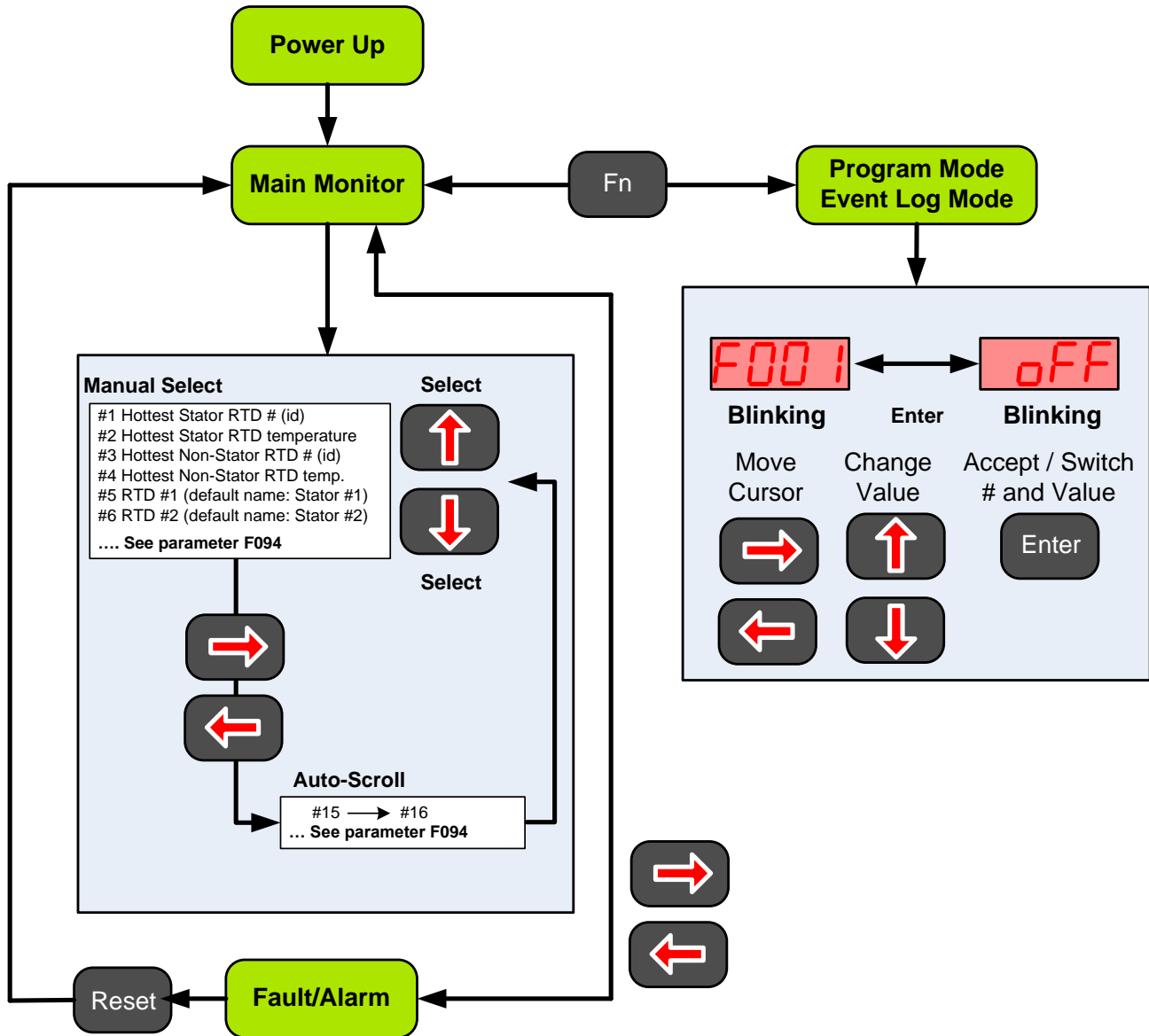

1.5 Quick Start-up

Follow these steps to setup your TE-RTD12 device.

Step 1: Connect Power Supply

With the power-supply turned **OFF** connect a single phase power supply 110 – 240 Vac Nominal to terminal TB1 (1 = Ground, 2 = N, 3 = L) to power the TE-RTD12. See wiring diagram for connections.

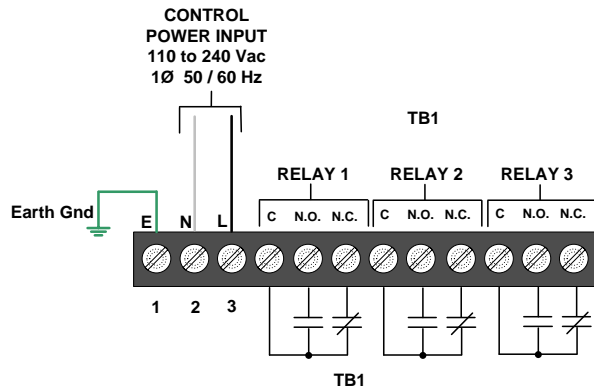

Important: Use fuse protection of 2A 240VAC 5kA RK5 or equivalent fuse for the input power supply.



CAUTION: DO NOT CONNECT INPUT POWER TO TB2, TB3, TB4, TB5, TB6 or TB7 ONLY CONNECT INPUT POWER TO TB1 TERMINAL N AND L (85 ~ 265Vac)

Step 2: Connect RTD Inputs (only if used)

- Turn power-supply **OFF**
- With the power-supply turned **OFF** connect the RTD inputs to terminal block TB3, TB4, TB5 and TB6 according to the wiring diagram.

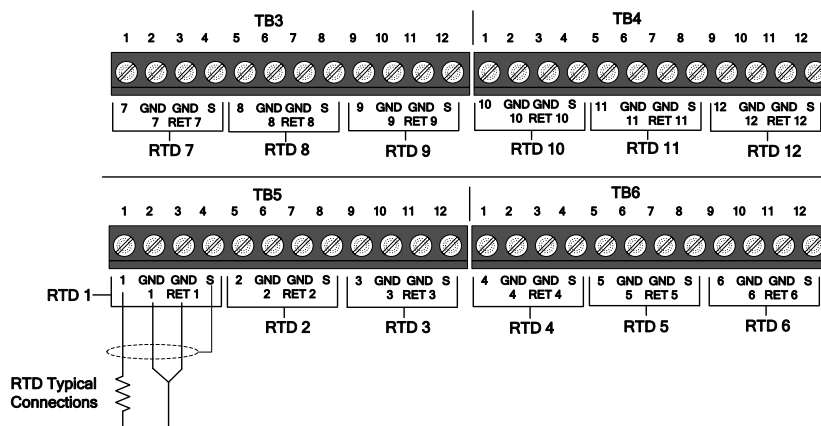

NOTE: The stator RTD's have to be connected consecutively from RTD #1 and up. The number of stator RTD's has to be entered in parameter F049.

Step 3: Program Unit

- Turn on power-supply.
- Set parameter F049 to # of used stator RTD's.
- To use temperature setting/readout in Fahrenheit, enter level 2 password (F102) = 2000, then set parameter F095 to '1' (default Fahrenheit).
- Set Real-time clock Date and Time, parameter F088 to F093.
- Enable RTD inputs 1 - 12 if used parameter F001, F005, F009, F013, F017, F021, F025, F029, F033, F037, F41 and F45.
- Set Alarm and Trip levels for RTD inputs F003, F004...F007, F008...F011, F012.

2.0 Parameters

2.1 Parameter Overview

Grp	RTD#	Fn#	Function	Adj. Range	Incr.	Default Setting	PSW Level
1. RTD Settings.	RTD1	F001	STATOR PHASE A1 TYPE	0-4 [0: OFF; 1: 100 Ohm Pt; 2: 10 Ohm Cu; 3: 100 Ohm Ni; 4: 120 Ohm Ni.]	1	OFF	1
		F002	RTD # 1 DESCRIPTION	0 -1 0: Stator #1 (StA1) 1: RTD #1 (rt 1)	1	0	1
		F003	STATOR PHASE A1 ALARM TEMPERATURE	0-464,[0-240 (C); 32-464 (F)], OFF	1	OFF	1
		F004	STATOR PHASE A1 TRIP TEMPERATURE	0-464,[0-240 (C); 32-464 (F)], OFF	1	OFF	1
	RTD2	F005	STATOR PHASE A2 TYPE	0-4 [0: OFF; 1: 100 Ohm Pt; 2: 10 Ohm Cu; 3: 100 Ohm Ni; 4: 120 Ohm Ni.]	1	OFF	1
		F006	RTD # 2 DESCRIPTION	0 -1 0: Stator #2 (StA2) 1: RTD #2 (rt 2)	1	0	1
		F007	STATOR PHASE A2 ALARM TEMPERATURE	0-464,[0-240 (C); 32-464 (F)], OFF	1	OFF	1
		F008	STATOR PHASE A2 TRIP TEMPERATURE	0-464,[0-240 (C); 32-464 (F)], OFF	1	OFF	1
	RTD3	F009	STATOR PHASE A3 TYPE	0-4 [0: OFF; 1: 100 Ohm Pt; 2: 10 Ohm Cu; 3: 100 Ohm Ni; 4: 120 Ohm Ni.]	1	OFF	1
		F010	RTD # 3 DESCRIPTION	0 -1 0: Stator #3 (StA3) 1: RTD #3 (rt 3)	1	0	1
		F011	STATOR PHASE A3 ALARM TEMPERATURE	0-464,[0-240 (C); 32-464 (F)], OFF	1	OFF	1
		F012	STATOR PHASE A3 TRIP TEMPERATURE	0-464,[0-240 (C); 32-464 (F)], OFF	1	OFF	1
	RTD4	F013	STATOR PHASE A4 TYPE	0-4 [0: OFF; 1: 100 Ohm Pt; 2: 10 Ohm Cu; 3: 100 Ohm Ni; 4: 120 Ohm Ni.]	1	OFF	1
		F014	RTD # 4 DESCRIPTION	0 -1 0: Stator #4 (StA4) 1: RTD #4 (rt 4)	1	0	1
		F015	STATOR PHASE A4 ALARM TEMPERATURE	0-464,[0-240 (C); 32-464 (F)], OFF	1	OFF	1
		F016	STATOR PHASE A4 TRIP TEMPERATURE	0-464,[0-240 (C); 32-464 (F)], OFF	1	OFF	1

Note: See parameter Fn95 first to change between °C and °F.

Grp	RTD#	Fn#	Function	Adj. Range	Incr.	Default Setting	PSW Level
1. RTD Settings.	RTD5	F017	STATOR PHASE A5 TYPE	0-4 [0: OFF; 1: 100 Ohm Pt; 2: 10 Ohm Cu; 3: 100 Ohm Ni; 4: 120 Ohm Ni.]	1	OFF	1
		F018	RTD # 5 DESCRIPTION	0-1 0: Stator #5 (StA5) 1: RTD #5 (rt 5)	1	0	1
		F019	STATOR PHASE A5 ALARM TEMPERATURE	0-464,[0-240 (C); 32-464 (F)], OFF	1	OFF	1
		F020	STATOR PHASE A5 TRIP TEMPERATURE	0-464,[0-240 (C); 32-464 (F)], OFF	1	OFF	1
	RTD6	F021	STATOR PHASE A6 TYPE	0-4 [0: OFF; 1: 100 Ohm Pt; 2: 10 Ohm Cu; 3: 100 Ohm Ni; 4: 120 Ohm Ni.]	1	OFF	1
		F022	RTD # 6 DESCRIPTION	0-1 0: Stator #6 (StA6) 1: RTD #6 (rt 6)	1	0	1
		F023	STATOR PHASE A6 ALARM TEMPERATURE	0-464,[0-240 (C); 32-464 (F)], OFF	1	OFF	1
		F024	STATOR PHASE A6 TRIP TEMPERATURE	0-464,[0-240 (C); 32-464 (F)], OFF	1	OFF	1
	RTD7	F025	FRONT BEARING TYPE	0-4 [0: OFF; 1: 100 Ohm Pt; 2: 10 Ohm Cu; 3: 100 Ohm Ni; 4: 120 Ohm Ni.]	1	OFF	1
		F026	RTD # 7 DESCRIPTION	0-1 0: Front Bearing (Fb) 1: RTD #7 (rt 7)	1	0	1
		F027	FRONT BEARING ALARM TEMPERATURE	0-464,[0-240 (C); 32-464 (F)], OFF	1	OFF	1
		F028	FRONT BEARING TRIP TEMPERATURE	0-464,[0-240 (C); 32-464 (F)], OFF	1	OFF	1
	RTD8	F029	REAR BEARING TYPE	0-4 [0: OFF; 1: 100 Ohm Pt; 2: 10 Ohm Cu; 3: 100 Ohm Ni; 4: 120 Ohm Ni.]	1	OFF	1
		F030	RTD # 8 DESCRIPTION	0-1 0: Rear Bearing (rb) 1: RTD #8 (rt 8)	1	0	1
		F031	REAR BEARING ALARM TEMPERATURE	0-464,[0-240 (C); 32-464 (F)], OFF	1	OFF	1
		F032	REAR BEARING TRIP TEMPERATURE	0-464,[0-240 (C); 32-464 (F)], OFF	1	OFF	1

Note: See parameter Fn95 first to change between °C and °F.

Grp	RTD#	Fn#	Function	Adj. Range	Incr.	Default Setting	PSW Level	
1. RTD Settings.	RTD9	F033	RTD #9 TYPE	0-4 [0: OFF; 1: 100 Ohm Pt; 2: 10 Ohm Cu; 3: 100 Ohm Ni; 4: 120 Ohm Ni.]	1	OFF	1	
		F034	RTD #9 DESCRIPTION	0 – 1 0: Bearing Box (brbo) 1: RTD #9 (rt 9)	1	0	1	
		F035	RTD #9 ALARM TEMPERATURE	0-464,[0-240 (C); 32-464 (F)], OFF	1	OFF	1	
		F036	RTD #9 TRIP TEMPERATURE	0-464,[0-240 (C); 32-464 (F)], OFF	1	OFF	1	
	RTD10	F037	RTD #10 TYPE	0-4 [0: OFF; 1: 100 Ohm Pt; 2: 10 Ohm Cu; 3: 100 Ohm Ni; 4: 120 Ohm Ni.]	1	OFF	1	
		F038	RTD #10 DESCRIPTION	0 – 1 0: Ambient (Abnt) 1: RTD #10 (rt10)	1	0	1	
		F039	RTD #10 ALARM TEMPERATURE	0-464,[0-240 (C); 32-464 (F)], OFF	1	OFF	1	
		F040	RTD #10 TRIP TEMPERATURE	0-464,[0-240 (C); 32-464 (F)], OFF	1	OFF	1	
	RTD11	F041	RTD #11 TYPE	0-4 [0: OFF; 1: 100 Ohm Pt; 2: 10 Ohm Cu; 3: 100 Ohm Ni; 4: 120 Ohm Ni.]	1	OFF	1	
		F042	RTD #11 DESCRIPTION	0 – 1 0: User Defined #1 (USr1) 1: RTD #11 (rt11)	1	0	1	
		F043	RTD #11 ALARM TEMPERATURE	0-464,[0-240 (C); 32-464 (F)], OFF	1	OFF	1	
		F044	RTD #11 TRIP TEMPERATURE	0-464,[0-240 (C); 32-464 (F)], OFF	1	OFF	1	
	RTD12	F045	RTD #12 TYPE	0-4 [0: OFF; 1: 100 Ohm Pt; 2: 10 Ohm Cu; 3: 100 Ohm Ni; 4: 120 Ohm Ni.]	1	OFF	1	
		F046	RTD #12 DESCRIPTION	0 – 1 0: User Defined #2 (USr2) 1: RTD #12 (rt12)	1	0	1	
		F047	RTD #12 ALARM TEMPERATURE	0-464,[0-240 (C); 32-464 (F)], OFF	1	OFF	1	
		F048	RTD #12 TRIP TEMPERATURE	0-464,[0-240 (C); 32-464 (F)], OFF	1	OFF	1	
			F049	# OF RTD'S USED FOR STATOR	0-6	1	6	
			F050	RTD VOTING	0 – 1 [0=Disabled, 1= Enabled]	1	0	1

Note: See parameter Fn95 first to change between °C and °F.

Grp	RTD#	Fn#	Function	Adj. Range	Incr.	Default Setting	PSW Level
2. Digital Inputs		F051	Input #1 (InP1) Select	0-2 [0: Disabled; 1: Normally Open; 2: Normally Closed]	1	0	1
		F052	Time Delay	1-60 (Sec)	1	1	1
		F053	Input #2 (InP2) Select	0-2 [0: Disabled; 1: Normally Open; 2: Normally Closed]	1	0	1
		F054	Time Delay	1-60 (Sec)	1	1	1
		F055	Input #3 (InP3) Select	0-2 [0: Disabled; 1: Normally Open; 2: Normally Closed]	1	0	1
		F056	Time Delay	1-60 (Sec)	1	1	1
3. Analog Inputs		F057	Analog Input #1 Name	0-5 [0: OFF; 1: Analog Input #1 (AnA1); 2: Oscillation #1 (oSC1); 3: Air Flow #1 (AFL1); 4: Speed #1 (SPd1); 5: Pressure #1 (PrS1).]	1	OFF	1
		F058	Analog Input #1 (AnA1) 4mA	0-9999	1	0	1
		F059	Analog Input #1 (AnA1) 20mA	0-9999	1	9999	1
		F060	Analog Input #1 Alarm Level	0,1-9999 [0: OFF; 1-9999 trip level]	1	OFF	1
		F061	Analog Input #1 Alarm Time Delay	1-60 (Sec)	1	1	1
		F062	Analog Input #1 Trip Level	0,1-9999 [0: OFF; 1-9999 trip level]	1	OFF	1
		F063	Analog Input #1 Trip Time Delay	1-60 (Sec)	1	1	1
		F064	Analog Input #2 Name	0-5 [0: OFF; 1: Analog Input #2 (AnA2); 2: Oscillation #2 (oSC2); 3: Air Flow #2 (AFL2); 4: Speed #2 (SPd2); 5: Pressure #2 (PrS2).]	1	OFF	1
		F065	Analog Input #2 (AnA2) 4mA	0-9999	1	0	1
		F066	Analog Input #2 (AnA2) 20mA	0-9999	1	9999	1
		F067	Analog Input #2 Alarm Level	0,1-9999 [0: OFF; 1-9999 trip level]	1	OFF	1
		F068	Analog Input #2 Alarm Time Delay	1-60 (Sec)	1	1	1
		F069	Analog Input #2 Trip Level	0,1-9999 [0: OFF; 1-9999 trip level]	1	OFF	1

Note: See parameter Fn95 first to change between °C and °F.

Grp	RTD#	Fn#	Function	Adj. Range	Incr.	Default Setting	PSW Level
4. Analog Output		F070	Analog Input #2 Trip Time Delay	1-60 (Sec)	1	1	1
		F071	Analog Output	0-6 [0: OFF; 1: Hottest Stator RTD Temperature; 2. Hottest Non-Stator RTD Temperature; 3. Analog Input #1 (AnA1); 4: Analog Input #2 (AnA2); 5: Unit Internal Temperature; 6: Highest Differential Phase Current.]	1	OFF	1
		F072	Analog Output 4mA	0-9999	1	0	1
		F073	Analog Output 20mA	0-9999	1	9999	1
5. Device Setting		F074	Unit Internal Alarm Temperature	0-257 [1-125(C), 32-257(F),OFF]	1	50	1
		F075	Reserved	-	-	-	-
6. Differential CTs		F076	Differential CT Alarm Level	OFF, 5-90 (% of CT Primary)	5	OFF	1
		F077	Alarm Time Delay	1-60 (Sec)	1	1	1
		F078	Differential CT Trip Level	OFF, 5-90 (% of CT Primary)	5	OFF	1
		F079	Trip Time Delay	1-60 (Sec)	1	1	1
		F080	Differential CT Primary	OFF, 5-2000 (A)	5	OFF	2
		F081	Differential CT Secondary	1,5 (A)	4	5	2
7. Relay Settings		F082	Relay 1 setting	Operation # 19 only	1	19 (Any Trip)	1
		F083	Relay 2 setting	Operation # 1 – 19	1	9 (Any Alarm)	1
		F084	Relay 3 setting	Operation # 1 – 19	1	13 (Digital Input #1 Trip)	1
8. Comm.		F085	Communications	0-2 [0=OFF; 1=Enabled(11bit) communication only; 2=Enabled(10bit) comm. only;]	1	OFF	2
		F086	Baud Rate	9.6, 19.2 and 38.4	-	9.6	2
		F087	Modbus Address	1 - 247	1	1	2
9. RTC		F088	Year	2000 - 2047	1 Year	-	1
		F089	Month	1-12	1 Month	-	1
		F090	Day	1-31	1 Day	-	1
		F091	Hour	0 - 23	1 Hour	-	1
		F092	Minute	0 - 59	1 Min.	-	1
		F093	Seconds	0 - 59	1 Sec.	-	1

Note: See parameter Fn95 first to change between °C and °F.

Grp	RTD#	Fn#	Function	Adj. Range	Incr.	Default Setting	PSW Level
10. Display		F094	Default Display	0-34 [0: Auto Scroll RTD Screens; 1-34: See Table of this Function]	1	1	2
		F095	Unit of Temperature	0-1 [0: C_ Celsius; 1: F_ Fahrenheit.]	1	0	2
11. Relay config.		F096	Relay 1 Fail Safe	0-1 [0=Disabled; 1=Enabled.]	1	0	2
		F097	Relay 2 Fail Safe	0-1 [0=Disabled; 1=Enabled.]	1	0	2
		F098	Relay 3 Fail Safe	0-1 [0=Disabled; 1=Enabled.]	1	0	2
		F099	Relay Test	0-3 [0=Disabled; 1=Energize Relay #1 for 5 seconds; 2=Energize Relay #2 for 5 seconds; 3=Energize Relay #3 for 5 seconds;]	1	0	2
12. System Settings		F100	Parameter Lock/ Level 1 Password	0, 001 – 999 [0= Disabled, Number=Password]	1	0(Show encrypted code)	1
		F101	System Clear / Factory Reset ^(TBD) (Reset Factory Default Settings)	0, 1 – 4 [0 = Disabled; 1=Clear Highest Temperature. 2= Reset Factory Default Settings in category of Level 1 Password. Level 1 Password required. 3 = Reset Factory Default Settings in categories of Level1 and Level 2 Password. Level 2 Password required. 4 = Reserved.]	1	0	1
		F102	Level 2 Password	2000 – 9999	1	2000 (Show encrypted code)	2
		F103	Reserved	-	-	-	-
13. Rev.		F104	RTD12 Revision #	-	-	-	
		F105	KP Revision #	-	-	-	
		F106	RTD-INF Revision #	-	-	-	

Note: See parameter Fn95 first to change between °C and °F.

Grp	RTD#	Fn#	Function	Adj. Range	Incr.	Default Setting	PSW Level
14. Fault History		F107	Fault History #1, Latest Fault	0, 31 – 50 (Fault #: see Fault code list; 0: No fault history)	1	0	
		F108	Alarm / Trip Level (if available)	---	-	-	
		F109	Time Stamp, Fault #1	EST 00.00-23.59 (hh.mm) [hh = 00-23; mm = 00-59]	00.01	00.00	
		F110	Date Stamp, Fault #1	01.01 – 12.31 (MM.DD) [MM = 01-12; DD = 01-31]	00.01	01.01	
		F111	Fault History #2, Previous Fault	0, 31 – 50 (Fault #: see Fault code list; 0: No fault history)	1	0	
		F112	Alarm / Trip Level (if available)	---	-	-	
		F113	Time Stamp, Fault #2	EST 00.00-23.59 (hh.mm) [hh = 00-23; mm = 00-59]	00.01	00.00	
		F114	Date Stamp, Fault #2	01.01 – 12.31 (MM.DD) [MM = 01-12; DD = 01-31]	00.01	01.01	
		F115	Fault History #3, Oldest Fault	0, 31 – 50 (Fault #: see Fault code list; 0: No fault history)	1	0	
		F116	Alarm / Trip Level (if available)	---	-	-	
		F117	Time Stamp, Fault #3	EST 00.00-23.59 (hh.mm) [hh = 00-23; mm = 00-59]	00.01	00.00	
		F118	Date Stamp, Fault #3	01.01 – 12.31 (MM.DD) [MM = 01-12; DD = 01-31]	00.01	01.01	
15. Event Record		F119	Present Event Record Number	0-447 [0: Null Rec; Others 1 – 447: Rec of Cycling Buffer. 4 parameters per Rec]			
		F120	Select Event Record Number [to navigate the record]	1-447 [Point to the Rec in Cycling Buffer. Total 447 Rec. 4 parameters per Rec]			2
		F121	Fault Code	1 st parameter in Rec. (See Fault Code List for fault code definitions.)			
		F122	Alarm / Trip Level (if available)	2 nd			
		F123	Time Stamp of Selected Event Record	3 rd : 00.00-23.59 (hh.mm) [hh = 00-23; mm = 00-59]			
		F124	Date Stamp of Selected Event Record	4 th (last): 01.01 – 12.31 (MM.DD) [MM = 01-12; DD = 01-31]			

Note: See parameter Fn95 first to change between °C and °F.

Table 3

2.2 Parameter Detailed Explanation

2.2.1 RTD Settings

F001 - STATOR PHASE A1 TYPE SELECTION (0 – 4), Default Setting: 0 - OFF

Select RTD #1 Type

Setting	Type
0	OFF
1	100 Ohm Pt (Platinum RTD)
2	10 Ohm Cu (Copper RTD)
3	100 Ohm Ni (Nickel RTD)
4	120 Ohm Ni (Nickel RTD)

F002 - RTD #1 DESCRIPTION SELECTION

Select RTD Description Selection (0 – 1), Default Setting: 0 – Stator #1 (StA1)

Setting	Assignment
0	Stator #1 (StA1)
1	RTD #1 (rt 1)

F003 - RTD #1 STATOR PHASE A1 ALARM TEMPERATURE (0 – 464), Default Setting: OFF

Set RTD Temperature Alarm Level. When the RTD temperature reached this level Alarm “**ALAr St 1**” or “**ALAr rt 1**” is shown on the keypad display. The Level can be programmed in Celsius or Fahrenheit depending on the setting of F095.

Range 0 – 240 Degrees Celsius (F095 = 0)
 Range 32 – 464 Degrees Fahrenheit (F095 = 1)

F004 - RTD #1 STATOR PHASE A1 TRIP TEMPERATURE (0 – 464), Default Setting: OFF

Set RTD Temperature trip Level. When the RTD temperature reached this level trip “**triP St 1**” or “**triP rt 1**” is shown on the keypad display. The Level can be programmed in Celsius or Fahrenheit depending on the setting of F095.

Range 0 – 240 Degrees Celsius (F095 = 0)
 Range 32 – 464 Degrees Fahrenheit (F095 = 1)

F005 - STATOR PHASE A1 TYPE SELECTION (0 – 4), Default Setting: 0 - OFF

Select RTD #2 Type

Setting	Type
0	OFF
1	100 Ohm Pt (Platinum RTD)
2	10 Ohm Cu (Copper RTD)
3	100 Ohm Ni (Nickel RTD)
4	120 Ohm Ni (Nickel RTD)

F006 - RTD #2 DESCRIPTION SELECTION

Select RTD Description Selection (0 – 1), Default Setting: 0 – Stator #2 (StA2)

Setting	Assignment
0	Stator #2 (StA2)
1	RTD #2 (rt 2)

F007 - RTD #2 STATOR PHASE A2 ALARM TEMPERATURE (0 – 464), Default Setting: OFF

Set RTD Temperature Alarm Level. When the RTD temperature reached this level Alarm “**ALAr St 2**” or “**ALAr rt 2**” is shown on the keypad display. The Level can be programmed in Celsius or Fahrenheit depending on the setting of F095.

Range 0 – 240 Degrees Celsius (F095 = 0)
 Range 32 – 464 Degrees Fahrenheit (F095 = 1)

F008 - RTD #2 STATOR PHASE A2 TRIP TEMPERATURE (0 – 464), Default Setting: OFF

Set RTD Temperature trip Level. When the RTD temperature reached this level trip “**triP St 2**” or “**triP rt 2**” is shown on the keypad display. The Level can be programmed in Celsius or Fahrenheit depending on the setting of F095.

Range 0 – 240 Degrees Celsius (F095 = 0)
 Range 32 – 464 Degrees Fahrenheit (F095 = 1)

F009 - STATOR PHASE A3 TYPE SELECTION (0 – 4), Default Setting: 0 - OFF

Select RTD #3 Type

Setting	Type
0	OFF
1	100 Ohm Pt (Platinum RTD)
2	10 Ohm Cu (Copper RTD)
3	100 Ohm Ni (Nickel RTD)
4	120 Ohm Ni (Nickel RTD)

F010 - RTD #3 DESCRIPTION SELECTION

Select RTD Description Selection (0 – 1), Default Setting: 0 – Stator #3 (StA3)

Setting	Assignment
0	Stator #3 (StA3)
1	RTD #3 (rt 3)

F011 - RTD #3 STATOR PHASE A3 ALARM TEMPERATURE (0 – 464), Default Setting: OFF

Set RTD Temperature Alarm Level. When the RTD temperature reached this level Alarm “**ALAr St 3**” or “**ALAr rt 3**” is shown on the keypad display. The Level can be programmed in Celsius or Fahrenheit depending on the setting of F095.

Range 0 – 240 Degrees Celsius (F095 = 0)
 Range 32 – 464 Degrees Fahrenheit (F095 = 1)

F012 - RTD #3 STATOR PHASE A3 TRIP TEMPERATURE (0 – 464), Default Setting: OFF

Set RTD Temperature trip Level. When the RTD temperature reached this level trip “**triP St 3**” or “**triP rt 3**” is shown on the keypad display. The Level can be programmed in Celsius or Fahrenheit depending on the setting of F095.

Range 0 – 240 Degrees Celsius (F095 = 0)
 Range 32 – 464 Degrees Fahrenheit (F095 = 1)

F013 - STATOR PHASE A4 TYPE SELECTION (0 – 4), Default Setting: 0 - OFF

Select RTD #4 Type

Setting	Type
0	OFF
1	100 Ohm Pt (Platinum RTD)
2	10 Ohm Cu (Copper RTD)
3	100 Ohm Ni (Nickel RTD)
4	120 Ohm Ni (Nickel RTD)

F014 - RTD #4 DESCRIPTION SELECTION

Select RTD Description Selection (0 – 1), Default Setting: 0 – Stator #4 (StA4)

Setting	Assignment
0	Stator #4 (StA4)
1	RTD #4 (rt 4)

F015 - RTD #4 STATOR PHASE A4 ALARM TEMPERATURE (0 – 464), Default Setting: OFF

Set RTD Temperature Alarm Level. When the RTD temperature reached this level Alarm “**ALAr St 4**” or “**ALAr rt 4**” is shown on the keypad display. The Level can be programmed in Celsius or Fahrenheit depending on the setting of F095.

Range 0 – 240 Degrees Celsius (F095 = 0)
 Range 32 – 464 Degrees Fahrenheit (F095 = 1)

F016 - RTD #4 STATOR PHASE A4 TRIP TEMPERATURE (0 – 464), Default Setting: OFF

Set RTD Temperature trip Level. When the RTD temperature reached this level trip “**triP St 4**” or “**triP rt 4**” is shown on the keypad display. The Level can be programmed in Celsius or Fahrenheit depending on the setting of F095.

Range 0 – 240 Degrees Celsius (F095 = 0)
 Range 32 – 464 Degrees Fahrenheit (F095 = 1)

F017 - STATOR PHASE A5 TYPE SELECTION (0 – 4), Default Setting: 0 - OFF

Select RTD #5 Type

Setting	Type
0	OFF
1	100 Ohm Pt (Platinum RTD)
2	10 Ohm Cu (Copper RTD)
3	100 Ohm Ni (Nickel RTD)
4	120 Ohm Ni (Nickel RTD)

F018 - RTD #5 DESCRIPTION SELECTION

Select RTD Description Selection (0 – 1), Default Setting: 0 – Stator #5 (StA5)

Setting	Assignment
0	Stator #5 (StA5)
1	RTD #5 (rt 5)

F019 - RTD #5 STATOR PHASE A5 ALARM TEMPERATURE (0 – 464), Default Setting: OFF

Set RTD Temperature Alarm Level. When the RTD temperature reached this level Alarm “**ALAr St 5**” or “**ALAr rt 5**” is shown on the keypad display. The Level can be programmed in Celsius or Fahrenheit depending on the setting of F095.

Range 0 – 240 Degrees Celsius (F095 = 0)
 Range 32 – 464 Degrees Fahrenheit (F095 = 1)

F020 - RTD #5 STATOR PHASE A5 TRIP TEMPERATURE (0 – 464), Default Setting: OFF

Set RTD Temperature trip Level. When the RTD temperature reached this level trip “**triP St 5**” or “**triP rt 5**” is shown on the keypad display. The Level can be programmed in Celsius or Fahrenheit depending on the setting of F095.

Range 0 – 240 Degrees Celsius (F095 = 0)
 Range 32 – 464 Degrees Fahrenheit (F095 = 1)

F021 - STATOR PHASE A6 TYPE SELECTION (0 – 4), Default Setting: 0 - OFF

Select RTD #6 Type

Setting	Type
0	OFF
1	100 Ohm Pt (Platinum RTD)
2	10 Ohm Cu (Copper RTD)
3	100 Ohm Ni (Nickel RTD)
4	120 Ohm Ni (Nickel RTD)

F022 - RTD #6 DESCRIPTION SELECTION

Select RTD Description Selection (0 – 1), Default Setting: 0 – Stator #6 (StA6)

Setting	Assignment
0	Stator #6 (StA6)
1	RTD #6 (rt 6)

F023 - RTD #6 STATOR PHASE A6 ALARM TEMPERATURE (0 – 464), Default Setting: OFF

Set RTD Temperature Alarm Level. When the RTD temperature reached this level Alarm “**ALAr St 6**” or “**ALAr rt 6**” is shown on the keypad display. The Level can be programmed in Celsius or Fahrenheit depending on the setting of F095.

Range 0 – 240 Degrees Celsius (F095 = 0)
 Range 32 – 464 Degrees Fahrenheit (F095 = 1)

F024 - RTD #6 STATOR PHASE A6 TRIP TEMPERATURE (0 – 464), Default Setting: OFF

Set RTD Temperature trip Level. When the RTD temperature reached this level trip “**triP St 6**” or “**triP rt 6**” is shown on the keypad display. The Level can be programmed in Celsius or Fahrenheit depending on the setting of F095.

Range 0 – 240 Degrees Celsius (F095 = 0)
 Range 32 – 464 Degrees Fahrenheit (F095 = 1)

F025 – FRONT BEARING TYPE SELECTION (0 – 4), Default Setting: 0 - OFF

Select RTD #7 Type

Setting	Type
0	OFF
1	100 Ohm Pt (Platinum RTD)
2	10 Ohm Cu (Copper RTD)
3	100 Ohm Ni (Nickel RTD)
4	120 Ohm Ni (Nickel RTD)

F026 - RTD #7 DESCRIPTION SELECTION

Select RTD Description Selection (0 – 1), Default Setting: 0 – Front Bearing (Fb)

Setting	Assignment
0	Front Bearing (Fb)
1	RTD #7 (rt 7)

F027 - RTD #7 FRONT BEARING ALARM TEMPERATURE (0 – 464), Default Setting: OFF

Set RTD Temperature Alarm Level. When the RTD temperature reached this level Alarm “**ALAr Fb**” or “**ALAr rt 7**” is shown on the keypad display. The Level can be programmed in Celsius or Fahrenheit depending on the setting of F095.

Range 0 – 240 Degrees Celsius (F095 = 0)
 Range 32 – 464 Degrees Fahrenheit (F095 = 1)

F028 - RTD #7 FRONT BEARING TRIP TEMPERATURE (0 – 464), Default Setting: OFF

Set RTD Temperature trip Level. When the RTD temperature reached this level trip “**triP Fb**” or “**triP rt 7**” is shown on the keypad display. The Level can be programmed in Celsius or Fahrenheit depending on the setting of F095.

Range 0 – 240 Degrees Celsius (F095 = 0)
 Range 32 – 464 Degrees Fahrenheit (F095 = 1)

F029 – REAR BEARING TYPE SELECTION (0 – 4), Default Setting: 0 - OFF

Select RTD #8 Type

Setting	Type
0	OFF
1	100 Ohm Pt (Platinum RTD)
2	10 Ohm Cu (Copper RTD)
3	100 Ohm Ni (Nickel RTD)
4	120 Ohm Ni (Nickel RTD)

F030 - RTD #8 DESCRIPTION SELECTION

Select RTD Description Selection (0 – 1), Default Setting: 0 – Rear Bearing (rb)

Setting	Assignment
0	Rear Bearing (rb)
1	RTD #8 (rt 8)

F031 - RTD #8 REAR BEARING ALARM TEMPERATURE (0 – 464), Default Setting: OFF

Set RTD Temperature Alarm Level. When the RTD temperature reached this level Alarm “**ALAr rb**” or “**ALAr rt 8**” is shown on the keypad display. The Level can be programmed in Celsius or Fahrenheit depending on the setting of F095.

Range 0 – 240 Degrees Celsius (F095 = 0)
 Range 32 – 464 Degrees Fahrenheit (F095 = 1)

F032 - RTD #8 REAR BEARING TRIP TEMPERATURE (0 – 464), Default Setting: OFF

Set RTD Temperature trip Level. When the RTD temperature reached this level trip “**triP rb**” or “**triP rt 8**” is shown on the keypad display. The Level can be programmed in Celsius or Fahrenheit depending on the setting of F095.

Range 0 – 240 Degrees Celsius (F095 = 0)
 Range 32 – 464 Degrees Fahrenheit (F095 = 1)

F033 – RTD #9 TYPE SELECTION (0 – 4), Default Setting: 0 - OFF

Select RTD #9 Type

Setting	Type
0	OFF
1	100 Ohm Pt (Platinum RTD)
2	10 Ohm Cu (Copper RTD)
3	100 Ohm Ni (Nickel RTD)
4	120 Ohm Ni (Nickel RTD)

F034 - RTD #9 DESCRIPTION SELECTION

Select RTD Description Selection (0 – 1), Default Setting: 0 – Bearing Box (brbo)

Setting	Assignment
0	Bearing Box (brbo)
1	RTD #9 (rt 9)

F035 - RTD #9 ALARM TEMPERATURE (0 – 464), Default Setting: OFF

Set RTD Temperature Alarm Level. When the RTD temperature reached this level Alarm “**ALAr brbo**” or “**ALAr rt 9**” is shown on the keypad display. The Level can be programmed in Celsius or Fahrenheit depending on the setting of F095.

Range 0 – 240 Degrees Celsius (F095 = 0)
 Range 32 – 464 Degrees Fahrenheit (F095 = 1)

F036 - RTD #9 TRIP TEMPERATURE (0 – 464), Default Setting: OFF

Set RTD Temperature trip Level. When the RTD temperature reached this level trip “**triP brbo**” or “**triP rt 9**” is shown on the keypad display. The Level can be programmed in Celsius or Fahrenheit depending on the setting of F095.

Range 0 – 240 Degrees Celsius (F095 = 0)
 Range 32 – 464 Degrees Fahrenheit (F095 = 1)

F037 – RTD #10 TYPE SELECTION (0 – 4), Default Setting: 0 - OFF

Select RTD #10 Type

Setting	Type
0	OFF
1	100 Ohm Pt (Platinum RTD)
2	10 Ohm Cu (Copper RTD)
3	100 Ohm Ni (Nickel RTD)
4	120 Ohm Ni (Nickel RTD)

F038 - RTD #10 DESCRIPTION SELECTION

Select RTD Description Selection (0 – 1), Default Setting: 0 – Ambient (Abnt)

Setting	Assignment
0	Ambient (Abnt)
1	RTD #10 (rt 10)

F039 - RTD #10 ALARM TEMPERATURE (0 – 464), Default Setting: OFF

Set RTD Temperature Alarm Level. When the RTD temperature reached this level Alarm “**ALAr Abnt**” or “**ALAr rt10**” is shown on the keypad display. The Level can be programmed in Celsius or Fahrenheit depending on the setting of F095.

Range 0 – 240 Degrees Celsius (F095 = 0)
 Range 32 – 464 Degrees Fahrenheit (F095 = 1)

F040 - RTD #10 TRIP TEMPERATURE (0 – 464), Default Setting: OFF

Set RTD Temperature trip Level. When the RTD temperature reached this level trip “**triP Abnt**” or “**triP rt10**” is shown on the keypad display. The Level can be programmed in Celsius or Fahrenheit depending on the setting of F095.

Range 0 – 240 Degrees Celsius (F095 = 0)
 Range 32 – 464 Degrees Fahrenheit (F095 = 1)

F041 – RTD #11 TYPE SELECTION (0 – 4), Default Setting: 0 - OFF

Select RTD #11 Type

Setting	Type
0	OFF
1	100 Ohm Pt (Platinum RTD)
2	10 Ohm Cu (Copper RTD)
3	100 Ohm Ni (Nickel RTD)
4	120 Ohm Ni (Nickel RTD)

F042 - RTD #11 DESCRIPTION SELECTION

Select RTD Description Selection (0 – 1), Default Setting: 0 – User Defined (USr1)

Setting	Assignment
0	User Defined (USr1)
1	RTD #11 (rt 11)

F043 - RTD #11 ALARM TEMPERATURE (0 – 464), Default Setting: OFF

Set RTD Temperature Alarm Level. When the RTD temperature reached this level Alarm “**ALAr USr1**” or “**ALAr rt11**” is shown on the keypad display. The Level can be programmed in Celsius or Fahrenheit depending on the setting of F095.

Range 0 – 240 Degrees Celsius (F095 = 0)
 Range 32 – 464 Degrees Fahrenheit (F095 = 1)

F044 - RTD #11 TRIP TEMPERATURE (0 – 464), Default Setting: OFF

Set RTD Temperature trip Level. When the RTD temperature reached this level trip “**triP USr1**” “**triP rt11**” is shown on the keypad display. The Level can be programmed in Celsius or Fahrenheit depending on the setting of F095.

Range 0 – 240 Degrees Celsius (F095 = 0)
 Range 32 – 464 Degrees Fahrenheit (F095 = 1)

F045 – RTD #12 TYPE SELECTION (0 – 4), Default Setting: 0 - OFF

Select RTD #12 Type

Setting	Type
0	OFF
1	100 Ohm Pt (Platinum RTD)
2	10 Ohm Cu (Copper RTD)
3	100 Ohm Ni (Nickel RTD)
4	120 Ohm Ni (Nickel RTD)

F046 - RTD #12 DESCRIPTION SELECTION

Select RTD Description Selection (0 – 1), Default Setting: 0 – User Defined (USr2)

Setting	Assignment
0	User Defined (USr2)
1	RTD #12 (rt 12)

F047 - RTD #12 ALARM TEMPERATURE (0 – 464), Default Setting: OFF

Set RTD Temperature Alarm Level. When the RTD temperature reached this level Alarm “**ALAr USr2**” or “**ALAr rt12**” is shown on the keypad display. The Level can be programmed in Celsius or Fahrenheit depending on the setting of F095.

Range 0 – 240 Degrees Celsius (F095 = 0)
 Range 32 – 464 Degrees Fahrenheit (F095 = 1)

F048 - RTD #12 TRIP TEMPERATURE (0 – 464), Default Setting: OFF

Set RTD Temperature trip Level. When the RTD temperature reached this level trip “**trip USr2**” or “**trip rt12**” is shown on the keypad display. The Level can be programmed in Celsius or Fahrenheit depending on the setting of F095.

Range 0 – 240 Degrees Celsius (F095 = 0)
 Range 32 – 464 Degrees Fahrenheit (F095 = 1)

F049 – NUMBER OF RTD’S USED FOR STATOR (0 – 6)

Set the number of RTD’s used for the stator, starting from RTD#1 (F001) to RTD#6 (F021)

F050 – RTD VOTING

Select RTD Voting Selection, Default Setting: 0 – Disabled

- RTD voting works only on Stator RTD’s (RTD #1 to RTD #6)
- When F050 is enabled, the TE-RTD12 will not post a trip until 2 RTD’s have exceeded their respective trip level. This prevents nuisance RTD tripping.

Setting	Function
0	Disabled
1	Enabled

2.2.2 Digital Inputs

The digital inputs are dry contact inputs. To activate a digital input connect a contact between GND and the desired digital input.

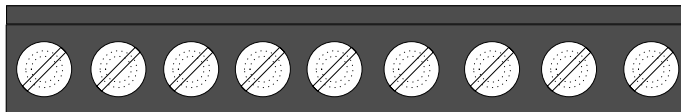
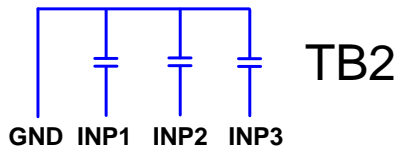

F051 – INPUT #1 (InP1) SELECTION (0 – 2), Default Setting: 0 - DISABLED

Select Input #1 Logic:

Setting	Function
0	Disabled
1	Normally Open
2	Normally Closed

F052 – INPUT #1 TIME DELAY

Set digital input #1 turn-on delay time (1 – 60 sec), Default Setting: 1 sec.

F053 – INPUT #2 (InP2) SELECTION (0 – 2), Default Setting: 0 - DISABLED

Select Input #2 Logic:

Setting	Function
0	Disabled
1	Normally Open
2	Normally Closed

F054 – INPUT #2 TIME DELAY

Set digital input #2 turn-on delay time (1 – 60 sec), Default Setting: 1 sec.

F055 – INPUT #3 (InP3) SELECTION (0 – 2), Default Setting: 0 - DISABLED

Select Input #3 Logic:

Setting	Function
0	Disabled
1	Normally Open
2	Normally Closed

F056 – INPUT #3 TIME DELAY

Set input #3 turn-on delay time (1 – 60 sec), Default Setting: 1 sec.

2.2.3 Analog Inputs

F057 – Analog Input #1 Name SELECTION (0 – 5), Default Setting: 0 - Off

Select assignment for analog input #1:

Setting	Assignment
0	Off
1	Analog Input #1 (AnA1) (User Defined)
2	Oscillation #1 (oSC1) (Vibration)
3	Airflow (AFL1) (in cfm)
4	Speed #1 (SPd1) (in RPM)
5	Pressure #1 (PrS1)

F058 – ANALOG INPUT #1 (Ana1) 4mA (0 – 9999), Default Setting: 0

Enter a value that the 4mA level will represent for the selected function; typically this value should be 0.

F059 – ANALOG INPUT #1 (Ana1) 20mA (0 – 9999), Default Setting: 9999

Enter a value that the 20mA level will represent for the selected function.

F060 – ANALOG INPUT #1 ALARM LEVEL (0 – 9999), Default Setting: OFF

Set Analog Input #1 Alarm Level. When the analog input scaled level rises above this level for the time delay programmed in F060 Alarm “**ALAr AnA1**” is shown on the keypad display.

F061 – ANALOG INPUT #1 ALARM TIME DELAY (1 – 60 sec), Default Setting: 1 sec.

Set Analog Input #1 Alarm time delay. When analog input #1 scaled level rises above the level set in F059 for the time delay programmed “**ALAr AnA1**” is shown on the keypad display

F062 – ANALOG INPUT #1 TRIP LEVEL (0 – 9999), Default Setting: OFF

Set Analog Input #1 Trip Level. When the analog input scaled level rises above this level for the time delay programmed in F062 Alarm “**triP AnA1**” is shown on the keypad display.

F063 – ANALOG INPUT #1 TRIP TIME DELAY (1 – 60 sec), Default Setting: 1 sec.

Set Analog Input #1 Trip time delay. When analog input #1 scaled level rises above the level set in F062 for the time delay programmed “**trip Ana1**” is shown on the keypad display

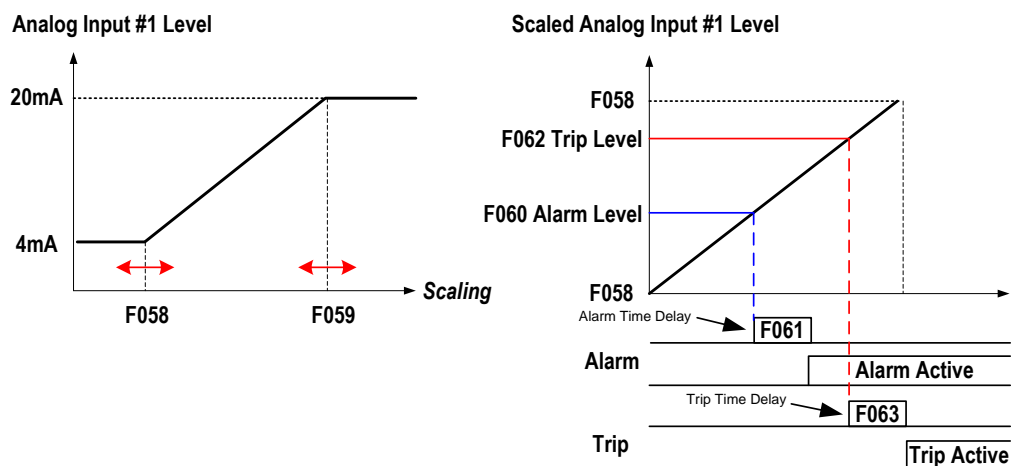

Example: Use Analog Input #1 to measure RPM of a motor with a maximum RPM of 3600.

- Set F057 to 4 (Speed)
- Set F058 to 0 (4mA = 0 RPM)
- Set F059 to 3600 (20mA = 3600 RPM)
- If needed set F060 for desired Alarm level
- If needed set F061 for desired Alarm delay time
- If needed set F062 for desired Trip level
- If needed set F063 for desired Trip delay time

F064 – Analog Input #2 Name SELECTION (0 – 5), Default Setting: 0 - Off

Select assignment for analog input #2:

Setting	Assignment
0	Off
1	Analog Input #2 (AnA2) (User Defined)
2	Oscillation #2 (oSC2) (Vibration)
3	Airflow (AFL2) (in cfm)
4	Speed #1 (SPd2) (in RPM)
5	Pressure #2 (PrS2)

F065 – ANALOG INPUT #2 (Ana2) 4mA (0 – 9999), Default Setting: 0

Enter a value that the 4mA level will represent for the selected function; typically this value should be 0.

F066 – ANALOG INPUT #2 (Ana2) 20mA (0 – 9999), Default Setting: 9999

Enter a value that the 20mA level will represent for the selected function.

F067 – ANALOG INPUT #2 ALARM LEVEL (0 – 9999), Default Setting: OFF

Set Analog Input #2 Alarm Level. When the analog input scaled level rises above this level for the time delay programmed in F066 Alarm “**ALAr AnA2**” is shown on the keypad display.

F068 – ANALOG INPUT #2 ALARM TIME DELAY (1 – 60 sec), Default Setting: 1 sec.

Set Analog Input #2 Alarm time delay. When analog input #2 scaled level rises above the level set in F65 for the time delay programmed “**ALAr AnA2**” is shown on the keypad display

F069 – ANALOG INPUT #2 TRIP LEVEL (0 – 9999), Default Setting: OFF

Set Analog Input #2 Trip Level. When the analog input scaled level rises above this level for the time delay programmed in F068 Alarm “**triP AnA2**” is shown on the keypad display.

F070 – ANALOG INPUT #2 TRIP TIME DELAY (1 – 60 sec), Default Setting: 1 sec.

Set Analog Input #2 Trip time delay. When analog input #2 scaled level rises above the level set in F067 for the time delay programmed “**triP AnA2**” is shown on the keypad display

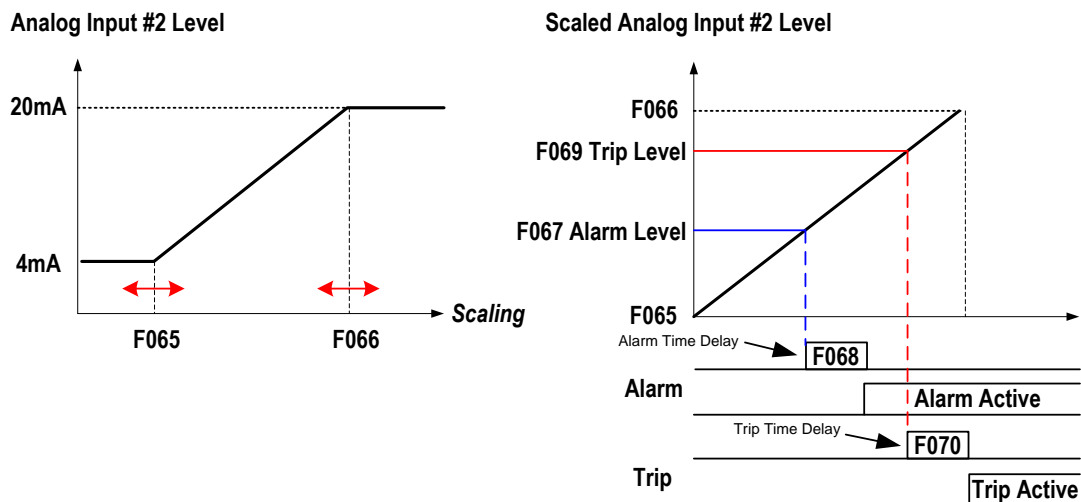

2.2.4 Analog Output

F071 – ANALOG OUTPUT SELECTION (0 – 6), Default Setting: 0 - OFF

Select Output #1 Assignment:

Setting	Assignment
0	OFF
1	Hottest Stator RTD Temperature
2	Hottest Non-Stator RTD Temperature
3	Analog Input #1 (AnA1)
4	Analog Input #2 (AnA2)
5	Unit Internal Temperature
6	Highest Differential Phase Current

F072 – ANALOG OUTPUT 4mA (0 – 9999), Default Setting: 0

Enter a value that the 4mA level will represent for the selected function; typically this value should be 0.

F073 – ANALOG OUTPUT 20mA (0 – 9999), Default Setting: 9999

Enter a value that the 20mA level will represent for the selected function.

Example: Use Analog Output to measure Hottest Stator RTD temperature

- Set F071 to 1 (Hottest Stator RTD)
- Set F072 to 32 (32deg F = 4mA)
- Set F073 to 464 (464deg F = 20mA)

Analog Output Level

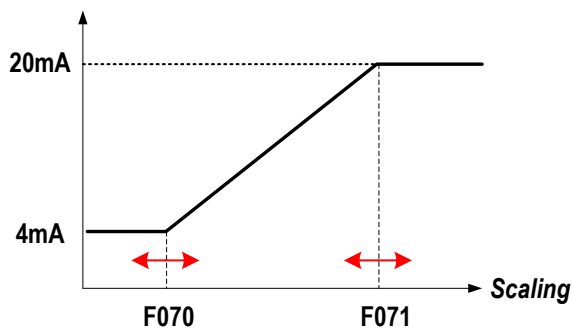

2.2.5 Device Setting

F074 – RTD UNIT INTERNAL ALARM TEMPERATURE LEVEL (0 – 257), Default Setting: 50

Set device temperature Alarm Level. When the device temperature reached this level Alarm “**ALAr Unit**” is shown on the keypad display. The Level can be programmed in Celsius or Fahrenheit depending on the setting of F095.

Range 1 – 125 Degrees Celsius (F095 = 0)
 Range 32 – 257 Degrees Fahrenheit (F095 = 1)

F075 – RESERVED

2.2.6 Differential CTs

The differential CT feature in the TE-RTD12 is designed to measure the leakage current of the motor windings. Maintenance can closely monitor any increase in leakage current to determine when to overhaul the motor.

Important: The differential CT feature is NOT designed to act as a UL Ground Fault or Over Current protection.

F076 – DIFFERENTIAL CT ALARM LEVEL (5 – 90%), Default Setting: OFF

Set Differential CT Alarm Level. The TE-RTD12 measures the current difference between incoming and outgoing current of each motor winding, when this value rises above this level for the time delay programmed in F077 Alarm “**ALAr diFX**” is shown on the keypad display.

F077 DIFFERENTIAL CT ALARM TIME DELAY (1 – 60 sec), Default Setting: 1 sec.

Set Differential CT Alarm time delay value.

F078 – DIFFERENTIAL CT TRIP LEVEL (OFF, 5 – 90%), Default Setting: OFF

Set Differential CT Trip Level. The TE-RTD12 measures the current difference between incoming and outgoing current of each motor winding, when this value rises above this level for the time delay programmed in F079 Trip “**triP diFX**” is shown on the keypad display.

F079 – DIFFERENTIAL CT TRIP TIME DELAY (1 – 60 sec), Default Setting: 1 sec.

Set Differential CT trip time delay value.

F080 – DIFFERENTIAL CT PRIMARY CURRENT VALUE (OFF, 5 – 2000A), Default Setting: 100A

Set CT primary value.

F081 – DIFFERENTIAL CT SECONDARY CURRENT VALUE (1, 5A), Default Setting: 5A

Set CT secondary value.

2.2.7 Relay Settings

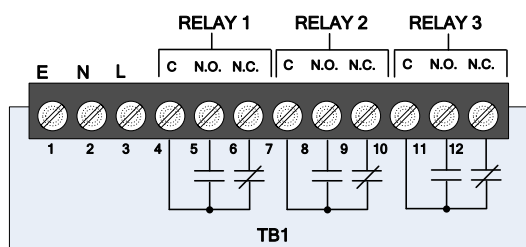

F082 – RELAY 1 SETTING (19), Fixed Setting: 19

Relay 1 is set to **ANY TRIP** only.

F083 – RELAY 2 SETTING (1 – 19), Default Setting: 9 – Any Alarm

Select relay 2 function from table 4.

F084 – RELAY 3 SETTING (1 – 19), Default Setting: 13 – Digital Input #1 Trip

Select relay 3 function from table 4.

Relay Functions

Setting	Function	Info
1	Stator RTD Alarm (ALAr StXX shown on display)	Unlatched
2	Non-Stator RTD Alarm (ALAr nSXX)	Unlatched
3	Any RTD Alarm (ALAr StXX) or (ALAr nSXX)	Unlatched
4	RTD Failure Alarm (ALAr rtXX)	Unlatched
5	Unit Over Temperature Alarm (ALAr Unit)	Unlatched
6	Analog Input #1 Alarm (ALAr AnA1)	Unlatched
7	Analog Input #2 Alarm (ALAr AnA2)	Unlatched
8	Differential Current Alarm (ALAr diFX)	Unlatched
9	Any Alarm (ALAr XXXX)	Unlatched
10	Stator RTD Trip (triP StXX)	Latched
11	Non-Stator RTD Trip (triP nStXX)	Latched
12	Any RTD Trip (triP StXX) or (triP nSXX)	Latched
13	Digital Input #1 Trip (triP InP1)	Latched
14	Digital Input #2 Trip (triP InP2)	Latched
15	Digital Input #3 Trip (triP InP3)	Latched
16	Analog Input #1 Trip (triP AnA1)	Latched
17	Analog Input #2 Trip (triP AnA2)	Latched
18	Differential Current Trip (triP diFX)	Latched
19	Any Trip (TriP XXXX)	Latched

Table 4

- Note:**
1. Alarm relays are not latched. (Relay will revert back if alarm condition clears)
 2. Trip relays are latched (Note: Required reset to clear the trip)
 3. F082 is Option #19 only.

2.2.8 Communication

F085 – COMMUNICATION SETUP (0 – 2), Default Setting: 0 - OFF

Select communication format.

Setting	Function
0	OFF
1	Enabled – 11bit communication (Standard)
2	Enabled – 10bit communication (1 Stop Bit)

F086 – BAUD RATE SELECTION (9.6 – 38.4 kBaud), Default Setting: 9.6 kBaud

Select communication format.

Setting	Function
9.6	9.6 kBaud
19.2	19.2 kBaud
38.4	38.4 kBaud

F087 – MODBUS ADDRESS (1 – 247), Default Setting: 1

Set MODBUS device address.

2.2.9 Real Time Clock

The built-in real time clock is used to record date and time for the event log.

F088 – YEAR (2000 – 2047)

Set real time clock year.

F089 – MONTH (1 – 12)

Set real time clock month of the current year.

F090 – DAY (1 – 31)

Set real time clock day of the current month.

F091 – HOUR (0 – 23)

Set real time clock hour of the current day.

F092 – MINUTE (0 – 59)

Set real time clock minute of the current hour.

F093 – SECONDS (0 – 59)

Set real time clock seconds of the current minute.

Important Note: Do not replace Real Time Clock internal battery, contact factory for support.

2.2.10 Display

F094 – DEFAULT DISPLAY (0 - 34), Default Setting: 1–Hottest Stator RTD#(id)

Set the display information on power-up.

Screen No.	Scroll Through Displays	Display 1	Display 2	Remark	Screen No.
#1	Hottest Stator RTD # (id)	HSid	01to (F049)		#1
#2	Hottest Stator RTD temperature	HSt	0000-1000		#2
#3	Hottest Non-Stator RTD # (id)	Hnid	(F049)+1 to 12		#3
#4	Hottest Non-Stator RTD temperature	HnSt	0000-1000		#4
#5	RTD #1 (default name: Stator #1)	(default: StA1)	[same as the above]	[Note 1,2]	#5
#6	RTD #2 (default name: Stator #2)	(default: StA 2)	[]	[Note 1,2]	#6
#7	RTD #3 (default name: Stator #3)	(default: StA3)	[]	[Note 1,2]	#7
#8	RTD #4 (default name: Stator #4)	(default: StA4)	[]	[Note 1,2]	#8
#9	RTD #5 (default name: Stator #5)	(default: StA5)	[]	[Note 1,2]	#9
#10	RTD #6 (default name: Stator #6)	(default: StA6)	[]	[Note 1,2]	#10
#11	RTD #7 (default name: Front Bearing)	(default: Fb)	[]	[Note 1,2]	#11
#12	RTD #8 (default name: Rear Bearing)	(default: rb)	[]	[Note 1,2]	#12
#13	RTD#9 (default name: Bearing Box)	(default: brbo)	[]	[Note 1,2]	#13
#14	RTD #10 (default name: Ambient Temperature)	(default: Abnt)	[]	[Note 1,2]	#14
#15	RTD #11 (default name: User Defined #1)	(default: USr1)	[]	[Note 1,2]	#15
#16	RTD #12 (default name: User Defined #2)	(default: USr2)	[]	[Note 1,2]	#16
#17	Highest Temperature Since Clear RTD #1	Hi 1	[]	[Note 1]	#17
#18	Highest Temperature Since Clear RTD #2	Hi 2	[]	[Note 1]	#18
#19	Highest Temperature Since Clear RTD #3	Hi 3	[]	[Note 1]	#19
#20	Highest Temperature Since Clear RTD #4	Hi 4	[]	[Note 1]	#20
#21	Highest Temperature Since Clear RTD #5	Hi 5	[]	[Note 1]	#21
#22	Highest Temperature Since Clear RTD #6	Hi 6	[]	[Note 1]	#22
#23	Highest Temperature Since Clear RTD #7	Hi 7	[]	[Note 1]	#23
#24	Highest Temperature Since Clear RTD #8	Hi 8	[]	[Note 1]	#24
#25	Highest Temperature Since Clear RTD #9	Hi 9	[]	[Note 1]	#25
#26	Highest Temperature Since Clear RTD #10	Hi10	[]	[Note 1]	#26
#27	Highest Temperature Since Clear RTD #11	Hi11	[]	[Note 1]	#27
#28	Highest Temperature Since Clear RTD #12	Hi12	[]	[Note 1]	#28
#29	Analog Input #1	AnA1	0000-9999	[Note 2]	#29
#30	Analog Input #2	AnA2	0000-9999	[Note 2]	#30
#31	Unit Internal Temperature	Unit	[]		#31
#32	Differential Current Phase A	DiFA	0.000-9999		#32
#33	Differential Current Phase B	DiFb	0.000-9999		#33
#34	Differential Current Phase C	DiFC	0.000-9999		#34

Note 1: While showing actual data on the display and no fault has occurred, pressing the left or right arrow buttons will alter scroll mode between manual and auto scroll mode. The actual data screens will only show the unit temperature and any of the active RTD values, active analog input values and active differential current values.

If F094 is set to “0”, after startup the display will auto scroll from screen #5 thru #16, #29, #30 and #32 thru #34. (Except for the functions turned off in their respective parameter)

At least 2 items have to be activated to enable auto scrolling.

Screens #17 thru #28 (Highest Temperature Since Clear RTD #xx) are only shown in manual mode, not in auto mode.

Note 2: #29 (Ana1) Analog Input 1 display set by F057, #30 (Ana2) Analog Input 2 display set by F064

F095 – UNIT OF TEMPERATURE (0 – 1), Default Setting: 0 - Celsius

Select temperature unit used for alarm levels, trip levels, event log and signal monitoring.

Setting	Function
0	Celsius
1	Fahrenheit

Note: It is important to select the temperature before programming any of the Alarm, Trip Levels and operating the device. Changing the temperature selection after programming requires trip and alarm settings to be reprogrammed to the correct temperature levels.

2.2.11 Relay Configuration

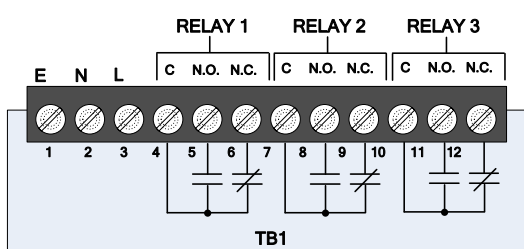

F096 – RELAY 1 FAIL SAFE (0 – 1), Default Setting: 0 - Disabled

Fail Safe Explanation: When a relay is configured as fail-safe and control power is applied to the RTD unit, the relay will energize and the relay contacts will change state. The relay will then de-energize when an event occurs or if the control power is removed from the RTD unit.

Select fail safe operation mode for Relay #1.

Setting	Function
0	Disabled
1	Enabled

F097 – RELAY 2 FAIL SAFE (0 – 1), Default Setting: 0 - Disabled

Select fail safe operation mode for Relay #2.

Setting	Function
0	Disabled
1	Enabled

F098 – RELAY 3 FAIL SAFE (0 – 1), Default Setting: 0 - Disabled

Select fail safe operation mode for Relay #3.

Setting	Function
0	Disabled
1	Enabled

F099 – RELAY TEST (0 – 3), Default Setting: 0 - Disabled



Important: Before performing the relay test, make sure it is safe to operate the relays.

Performing this test may cause equipment to be energized!!

Each of the available relays can be tested by setting this parameter. When enabled the selected relay will be energized for 5 sec before de-energizing.

Setting	Function
0	Disabled
1	Energize Relay #1 one time for 5 seconds
2	Energize Relay #2 one time for 5 seconds
3	Energize Relay #3 one time for 5 seconds

F100 – PARAMETER LOCK / LEVEL 1 PASSWORD (0 – 999), Default Setting: 0 - Disabled

Setting the level 1 password allows for locking the settings of Level 1 parameters. Please refer to the parameter table password level column of the parameter table for level of each parameter.

Note: When set, display of the value of F100 will show encrypted password value.

2.2.12 System Settings

F101 – SYSTEM CLEAR / FACTORY RESET (0 – 4), Default Setting: 0 - Disabled

Allows for clearing highest recorded temperature and resetting parameters to factory defaults.

Setting	Function
0	Disabled
1	Clear Highest Temperature
2	Reset Factory Default Settings for Level 1, Note Requires Level 1 Password F100
3	Reset Factory Default Settings for Level 1 and 2, Note Requires Level 2 Password F102

F102 – LEVEL 2 PASSWORD (2000 – 9999), Default Setting: 2000

Setting the level 2 password allows for locking the settings of Level 2 parameters. Please refer to the parameter table password level column of the parameter table for level of each parameter.

Note: When set, display of the value of F102 will show encrypted password value.

F103 – RESERVED

2.2.13 Device Information

F104 – TE-RTD12 REVISION #

Displays device firmware revision.

F105 – TE-RTD12 KEYPAD REVISION #

Displays device keypad firmware revision.

F106 – RTD-INF Revision #

Displays revision number of the interface board to interface the TE-RTD12 with the MVC CPU board. It emulates the old RTD board.

This only applies if the TE-RTD12 is interfaced with a MVC3 or MVC4 series of Medium Voltage Soft Starters, equipped with the RTD option board.

NOTES -

3.0 Fault History and Event Records

3.1 Fault History (Read Only)

F107 – FAULT HISTORY #1, LATEST FAULT (0, 31 – 50) see Fault Code Table 5.

Default Setting: 0 – No Fault: Displays the last fault.

F108 – TRIP LEVEL

Displays trip level of the last fault, if it is available.

F109 – TIME STAMP, FAULT #1

Displays the time fault #1 occurred.

F110 – DATE STAMP, FAULT #1

Displays the date fault #1 occurred.

F111 – FAULT HISTORY #2, PREVIOUS FAULT (0, 31 – 50) see Fault Code Table 5.

Default Setting: 0 – No Fault: Displays the previous fault.

F112 –TRIP LEVEL

Displays trip level of the previous fault, if it is available.

F113 – TIME STAMP, FAULT #2

Displays the time fault #2 occurred.

F114 – DATE STAMP, FAULT #2

Displays the date fault #2 occurred.

F115 – FAULT HISTORY #3, OLDEST FAULT (0, 31 – 50) see Fault Code Table 5..

Default Setting: 0 – No Fault: Displays the oldest fault.

F116 –TRIP LEVEL

Displays trip level of the oldest fault, if it is available.

F117 – TIME STAMP, FAULT #3

Displays the time fault #3 occurred.

F118 – DATE STAMP, FAULT #3

Displays the date fault #3 occurred.

3.2 Fault Code Table 5 for Fault History F107, F111, F115, and Event Record F121:

Fault Code	Description	Fault #
ALAr St 1 or ALAr rt 1	Stator #1 or RTD #1 Alarm	1
ALAr St 2 or ALAr rt 2	Stator #2 or RTD #2 Alarm	2
ALAr St 3 or ALAr rt 3	Stator #3 or RTD #3 Alarm	3
ALAr St 4 or ALAr rt 4	Stator #4 or RTD #4 Alarm	4
ALAr St 5 or ALAr rt 5	Stator #5 or RTD #5 Alarm	5
ALAr St 6 or ALAr rt 6	Stator #6 or RTD #6 Alarm	6
ALAr Fb or ALAr rt 7	Front Bearing or RTD #7 Alarm	7
ALAr rb or ALAr rt 8	Rear Bearing or RTD #8 Alarm	8
ALAr brbo or ALAr rt 9	Bearing Box or RTD #9 Alarm	9
ALAr Abnt or ALAr rt10	Ambient or RTD #10 Alarm	10
ALAr USr1 or ALAr rt11	User Defined #1 or RTD #11 Alarm	11
ALAr USr2 or ALAr rt12	User Defined #2 or RTD #12 Alarm	12
FAiL St 1 or FAiL rt 1	Stator # or RTD #1 Failure Alarm	13
FAiL St 2 or FAiL rt 2	Stator # or RTD #2 Failure Alarm	14
FAiL St 3 or FAiL rt 3	Stator # or RTD #3 Failure Alarm	15
FAiL St 4 or FAiL rt 4	Stator # or RTD #4 Failure Alarm	16
FAiL St 5 or FAiL rt 5	Stator # or RTD #5 Failure Alarm	17
FAiL St 6 or FAiL rt 6	Stator # or RTD #6 Failure Alarm	18
FAiL Fb or FAiL rt 7	Front Bearing or RTD #7 Failure Alarm	19
FAiL rb or FAiL rt 8	Rear Bearing or RTD #8 Failure Alarm	20
FAiL brbo or FAiL rt 9	Bearing Box or RTD #9 Failure Alarm	21
FAiL Abnt or FAiL rt10	Ambient or RTD #10 Failure Alarm	22
FAiL USr1 or FAiL rt11	User Defined #1 or RTD #11 Failure Alarm	23
FAiL USr2 or FAiL rt12	User Defined #2 or RTD #12 Failure Alarm	24
ALAr Unit	Unit Over Temperature Alarm	25
ALAr AnA1	Analog Input #1 Alarm	26
ALAr AnA2	Analog Input #2 Alarm	27
ALAr diFA	Differential Chan A Alarm	28
ALAr diFb	Differential Chan B Alarm	29
ALAr diFC	Differential Chan C Alarm	30
triP St 1 or triP rt 1	Stator #1 or RTD #1 Trip	31
triP St 2 or triP rt 2	Stator #2 or RTD #2 Trip	32
triP St 3 or triP rt 3	Stator #3 or RTD #3 Trip	33
triP St 4 or triP rt 4	Stator #4 or RTD #4 Trip	34
triP St 5 or triP rt 5	Stator #5 or RTD #5 Trip	35
triP St 6 or triP rt 6	Stator #6 or RTD #6 Trip	36
triP Fb or triP rt 7	Front Bearing or RTD #7 Trip	37
triP rb or triP rt 8	Rear Bearing or RTD #8 Trip	38
triP brbo or triP rt 9	Bearing Box or RTD #9 Trip	39
triP Abnt or triP rt10	Ambient or RTD #10 Trip	40
triP USr1 or triP rt11	User Defined #1 or RTD #11 Trip	41
triP USr2 or triP rt12	User Defined #2 or RTD #12 Trip	42
triP inP1	Digital Input #1 Trip	43
triP inP2	Digital Input #2 Trip	44
triP inP3	Digital Input #3 Trip	45
triP AnA1	Analog Input #1 Trip	46
triP AnA2	Analog Input #2 Trip	47
triP diFA	Differential Chan A Trip	48
triP diFb	Differential Chan B Trip	49
triP diFC	Differential Chan C Trip	50

3.3 Event Record (Read Only)

The last 447 events / alarms and/or faults are stored in the device, each event can be accessed by the read only parameters described below.

F119 – PRESENT EVENT RECORD POINTER (0 – 447)

Displays the latest event record. 0 = No Fault

F120 – SELECT EVENT RECORD (1 – 447)

Default Setting: 1 – Event Record 1 Selected

Set the active event record. Event data is displayed in read only parameters F121 – F124.

F121 – FAULT CODE (0, 1 - 50), see fault code table 5.

Default Setting: 0 – No Fault

Displays the fault code (see previous page) for the selected event record set by parameter F120.

F122 – ALARM / TRIP LEVEL

Displays alarm / trip level for the selected event record set by parameter F120, if the level is available.

F123 – TIME STAMP, SELECT EVENT RECORD

Displays the time stamp for the selected event record set by parameter F120.

F124 – DATE STAMP, SELECT EVENT RECORD

Displays the date stamp for the selected event record set by parameter F120.

The Event Recorder is accessible via the TE-RTD12 Mlink Software.

NOTES -

4.0 Modbus RTU Communication

The TE-RTD12 can be programmed and monitored via a serial connection using the MODBUS RTU protocol. The TE-RTD12 features an RS485, optically isolated half-duplex communication port.

4.1 Serial Connection / Wiring

The physical connection for serial communication uses a RJ45 connector.

RJ45 Terminal Connection:

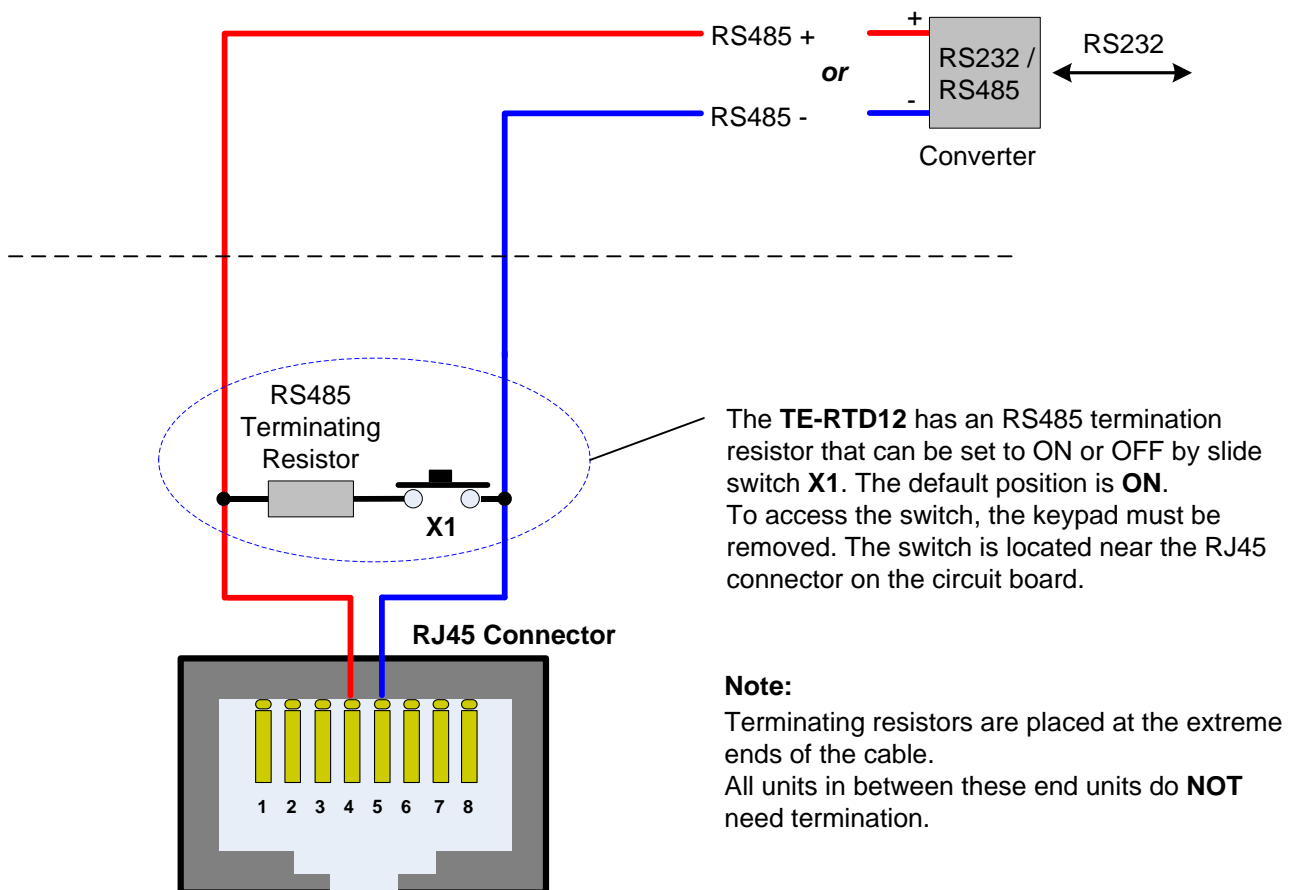

TE-RTD12 RS485 Serial Communication Connections

4.2 Serial Communication Settings

Follow these steps to setup communication with the TE-RTD12:

Step 1: Enable communication

Set Parameter F083 – Communication to a value of ‘1’ or ‘2’

Setting 1: Enabled, 8-bit, No Parity, 2 Stop bits (Standard)

Setting 2: Enabled, 8-bit, No Parity, 1 Stop bit

Step 2: Communication Speed

Set communication baud rate with parameter F086 – default 9600 baud

Step 3: Modbus Address / Device Address

Set modus address with parameter F087 – default ‘1’

4.3 MODBUS RTU Message Structure

The TE-RTD12 supports the following MODBUS RTU functions.

Function Code	TE-RTD12 Description	Modbus Description
3	Read Multiple Registers	Read Holding Registers
16	Write Multiple Registers	Preset Multiple Registers

Message format: Query of Function 3 - Read Multiple Registers (Instance)

Field Name (byte)	Decimal	Hexadecimal
Device Address	1	01
Function	3	03
Starting Data Address High Byte Starting Data Address Low Byte	1001	03 E9
Number of Registers High Byte Number of Registers Low Byte	2	00 02
CRC Low Byte CRC High Byte	47893	15 BB

Message Response of Function 3 - Read Multiple Registers (Instance)

Field Name (byte)	Decimal	Hexadecimal
Device Address	1	01
Function	3	03
Byte Count	4	04
Data High Byte of 1 st Register from Starting Data Address Data Low Byte of 1 st Register from Starting Data Address	22	00 16
Data High Byte of 2 nd Register from Starting Data Address Data Low Byte of 2 nd Register from Starting Data Address	100	00 64
CRC Low Byte CRC High Byte	7194	1A 1C

Note: The sum of Data High Bytes and Data Low Bytes equal the Byte Count.

Message Query of Function 16 - Write Multiple Registers (Instance)

Field Name (byte)	Decimal	Hexadecimal
Device Address	1	01
Function	16	10
Starting Data Address High Byte Starting Data Address Low Byte	1001	03 E9
Number of Registers High Byte Number of Registers Low Byte	2	00 02
Byte Count	4	04
Data High Byte of 1 st Register from Starting Data Address Data Low Byte of 1 st Register from Starting Data Address	23	00 17
Data High Byte of 2 nd Register from Starting Data Address Data Low Byte of 2 nd Register from Starting Data Address	105	00 69
CRC Low Byte CRC High Byte	22361	59 57

Note: The sum of Data High Bytes and Data Low Bytes equal the Byte Count (2 x Number of Registers).

Message Response of Function 16 - Write Multiple Registers (Instance)

Field Name (byte)	Decimal	Hexadecimal
Device Address	1	01
Function	16	10
Starting Data Address High Byte Starting Data Address Low Byte	1001	03 E9
Number of Registers High Byte Number of Registers Low Byte	2	00 02
CRC Low Byte CRC High Byte	30864	90 78

Exception Response Frame

In normal response, the function field will always return the same code as Query sent. However, in an Exception response, the code in function field will be added 80(hex) to represent an Exception response. See Table 2-6: Wrong Query of Function 3 - Read Multiple Registers (Instance) and Table 2-7 Response of the Wrong Function 3 Query. Also see Table 2-8: Exception Codes

Invalid Query for Function 3 - Read Multiple Registers (Instance)

Field Name (byte)	Decimal	Hexadecimal
Device Address	1	01
Function	3	03
Starting Data Address High Byte Starting Data Address Low Byte	1000	03 E8
Number of Registers High Byte Number of Registers Low Byte	1	00 01
CRC Low Byte CRC High Byte	31236	04 7A

Response to an invalid Function 3 Query

Field Name (byte)	Decimal	Hexadecimal
Device Address	1	01
Function	131	83
Exception Code	2	02
CRC Low Byte CRC High Byte	61888	C0 F1

Exception Codes

Exception Code	Name	Description
01	Illegal Function	The Function field of the query does not fall into the range which the slave supports. Function Codes 3 and 16 are supported.
02	Illegal Address	The data address existed in the query is out of the supported range.
03	Illegal Data Value	The data received from the host/master is invalid.
06	Busy	The device is busy. The master should re-try sending the message again.
16	Illegal Data Length	The field "Number of Registers" from the query is greater than the maximum allowed value of 18 limited.

4.4 Main Registers

Register Address	Register Name	Data Range	Data Incr.	Data Default	R/W	Remark	Setpoint Inc.	Setpoint Default
1001	STATOR PHASE A1 TYPE	0-4	1	0			1	OFF
1002	RTD # 1 DESCRIPTION	0-1	1	0			1	1
1003	STATOR PHASE A1 ALARM TEMPERATURE	0-464,465	1	465		Range varies with unit setting in F095. Same for all RTDs	1	OFF
1004	STATOR PHASE A1 TRIP TEMPERATURE	0-464,465	1	465		Range varies with unit setting in F095. Same for all RTDs	1	OFF
1005	STATOR PHASE A2 TYPE	0-4	1	0			1	OFF
1006	RTD # 2 DESCRIPTION	0-1	1	0			1	2
1007	STATOR PHASE A2 ALARM TEMPERATURE	0-464,465	1	465			1	OFF
1008	STATOR PHASE A2 TRIP TEMPERATURE	0-464,465	1	465			1	OFF
1009	STATOR PHASE A3 TYPE	0-4	1	0			1	OFF
1010	RTD # 3 DESCRIPTION	0-1	1	0			1	3
1011	STATOR PHASE A3 ALARM TEMPERATURE	0-464,465	1	465			1	OFF
1012	STATOR PHASE A3 TRIP TEMPERATURE	0-464,465	1	465			1	OFF
1013	STATOR PHASE A4 TYPE	0-4	1	0			1	OFF
1014	RTD # 4 DESCRIPTION	0-1	1	0			1	0
1015	STATOR PHASE A4 ALARM TEMPERATURE	0-464,465	1	465			1	OFF
1016	STATOR PHASE A4 TRIP TEMPERATURE	0-464,465	1	465			1	OFF
1017	STATOR PHASE A5 TYPE	0-4	1	0			1	OFF
1018	RTD # 5 DESCRIPTION	1-22	1	0			1	0
1019	STATOR PHASE A5 ALARM TEMPERATURE	0-464,465	1	465			1	OFF
1020	STATOR PHASE A5 TRIP TEMPERATURE	0-464,465	1	465			1	OFF
1021	STATOR PHASE A6 TYPE	0-4	1	0			1	OFF
1022	RTD # 6 DESCRIPTION	0-1	1	0			1	0
1023	STATOR PHASE A6 ALARM TEMPERATURE	0-464,465	1	465			1	OFF
1024	STATOR PHASE A6 TRIP TEMPERATURE	0-464,465	1	465			1	OFF
1025	FRONT BEARING TYPE	0-4	1	0			1	OFF
1026	RTD # 7 DESCRIPTION	0-1	1	0			1	0
1027	FRONT BEARING ALARM	0-464,465	1	465		May swap with	1	OFF

Register Address	Register Name	Data Range	Data Incr.	Data Default	R/W	Remark	Setpoint Inc.	Setpoint Default
	TEMPERATURE					Shaft Bearing		
1028	FRONT BEARING TRIP TEMPERATURE	0-464,465	1	465			1	OFF
1029	REAR BEARING TYPE	0-4	1	0			1	OFF
1030	RTD # 8 DESCRIPTION	0-1	1	0			1	0
1031	REAR BEARING ALARM TEMPERATURE	0-464,465	1	465			1	OFF
1032	REAR BEARING TRIP TEMPERATURE	0-464,465	1	465			1	OFF
1033	RTD #9 TYPE	0-4	1	0			1	OFF
1034	RTD #9 DESCRIPTION	0-1	1	0			1	0
1035	RTD #9 ALARM TEMPERATURE	0-464,465	1	465			1	OFF
1036	RTD #9 TRIP TEMPERATURE	0-464,465	1	465			1	OFF
1037	RTD #10 TYPE	0-4	1	0			1	OFF
1038	RTD #10 DESCRIPTION	0-1	1	0			1	0
1039	RTD #10 ALARM TEMPERATURE	0-464,465	1	465			1	OFF
1040	RTD #10 TRIP TEMPERATURE	0-464,465	1	465			1	OFF
1041	RTD #11 TYPE	0-4	1	0			1	OFF
1042	RTD #11 DESCRIPTION	0-1	1	0			1	0
1043	RTD #11 ALARM TEMPERATURE	0-464,465	1	465			1	OFF
1044	RTD #11 TRIP TEMPERATURE	0-464,465	1	465			1	OFF
1045	RTD #12 TYPE	0-4	1	0			1	OFF
1046	RTD #12 DESCRIPTION	0-1	1	0			1	0
1047	RTD #12 ALARM TEMPERATURE	0-464,465	1	465			1	OFF
1048	RTD #12 TRIP TEMPERATURE	0-464,465	1	465			1	OFF
1049	# OF RTD'S USED FOR STATOR	0-6	1	4		It is counted from RTD#1. All stator RTD# are less than or equal to it.	1	4
1050	RTD STATOR VOTING	0 – 1	1	0			1	0
1051	Input #1 (InP1) Select	0-2	1	0			1	0
1052	Time Delay	1-60	1	1			1	1
1053	Input #2 (InP2) Select	0-2	1	0			1	0
1054	Time Delay	1-60	1	1			1	1
1055	Input #2 (InP3) Select	0-2	1	0			1	0
1056	Time Delay	1-60	1	0			1	0

Register Address	Register Name	Data Range	Data Incr.	Data Default	R/W	Remark	Setpoint Inc.	Setpoint Default
1057	Analog Input #1 Name	0-5	1	0			1	0
1059	Analog Input #1 (AnA1) 4mA	0-9999	1	0			1	0
1059	Analog Input #1 (AnA1) 20mA	0-9999	1	9999			1	9999
1060	Analog Input #1 Alarm Level	0,1-9999	1	0			1	0
1061	Analog Input #1 Alarm Time Delay	1-60	1	1			1	1
1062	Analog Input #1 Trip Level	0,1-9999	1	0			1	0
1063	Analog Input #1 Trip Time Delay	1-60	1	1			1	1
1064	Analog Input #2 Name	0-5	1	0			1	0
1065	Analog Input #2 (AnA2) 4mA	0-9999	1	0			1	0
1066	Analog Input #2 (AnA2) 20mA	0-9999	1	9999			1	9999
1067	Analog Input #2 Alarm Level	0,1-9999	1	0			1	0
1068	Analog Input #2 Alarm Time Delay	1-60	1	1			1	1
1069	Analog Input #2 Trip Level	0,1-9999	1	0			1	0
1070	Analog Input #2 Trip Time Delay	1-60	1	1			1	1
1071	Analog Output	0-6	1	0			1	0
1072	Analog Output 4mA	0-9999	1	0			1	0
1073	Analog Output 20mA	0-9999	1	9999			1	9999
1074	Unit Alarm Temperature	0-257	1	50		Range varies with unit setting in F095.	1	50 Default 50 for Celsius
1075	Reserved							
1076	Differential CT Alarm Level	0, 5-90	5	0			5	0
1077	Alarm Time Delay	1-60	1	1			1	1
1078	Differential CT Trip Level	OFF, 5-90	5	0			5	OFF
1079	Trip Time Delay	1-60	1	1			1	1
1080	Differential CT Primary	OFF, 5-2000	5	0			5	OFF
1081	Differential CT Secondary	1,5	4	5			4	5
1082	Relay 1 setting	19	1	19 (Any Trip)			1	9 (Any Alarm)
1083	Relay 2 setting	1 – 19	1	9 (Any Alarm)			1	19 (Any Trip)
1084	Relay 3 setting	1 – 19	1	13 (Digital Input #1 Trip)			1	13 (Digital Input #1 Trip)
1085	Communications	0-2	1	0			1	0
1086	Baud Rate	0-3	1	1			Baud rate	9600

Register Address	Register Name	Data Range	Data Incr.	Data Default	R/W	Remark	Setpoint Inc.	Setpoint Default
1087	Modbus Address	1 - 247	1	1			1	1
1088	Year	2000 - 2047	1 year	-			1 year	-
1089	Month	1-12	1 Month	-			1 Month	-
1090	Day	1-31	1 Day	-			1 Day	-
1091	Hour	0 - 23	1 Hour	-			1 Hour	-
1092	Minute	0 - 59	1 Minute	-			1 Minute	-
1093	Seconds	0 - 59	1 Second	-			1 Second	-
1094	Default Display	0-34	1	1			1	1
1095	Unit of Temperature	0-1	1	0		Redo RTDs trip and alarm setting, if change here.	1	0
1096	Relay 1 Fail Safe	0-1	1	0			1	0
1097	Relay 2 Fail Safe	0-1	1	0			1	0
1098	Relay 3 Fail Safe	0-1	1	0			1	0
1099	Relay Test	0-3	1	0			1	0
1100	Parameter Lock/ Level 1 Password	0, 001 – 999	1	0(Show encrypted code)			1	0(Show encrypted code)
1101	System Clear / Factory Reset (Reset Factory Default Settings)	0, 1 – 4	1	0			1	0
1102	Level 2 Password	2000 – 9999	1	2000			1	2000 (Show encrypted code)
1103	Reserved							
1104	RTD12 Revision #	-	-	-		Read Only	-	-
1105	KP Revision #	-	-	-		Read Only	-	-
1106	RTD-INF Revision#	-	-	-		Read Only	-	-
1107	Fault History #1, Latest Fault	0,31 – 50	1	0		Read Only	1	0
1108	Alarm / Trip Level (if available)	0 - 9999	1	-		Read Only	-	-
1109	Time Stamp, Fault #1	00.00-23.59	00.01	00.00		Read Only	00.01	00.00
1110	Date Stamp, Fault #1	01.01 – 12.31	00.01	01.01		Read Only	00.01	01.01
1111	Fault History #2, Previous Fault	0, 31 – 50	1	0		Read Only	1	0
1112	Alarm / Trip Level (if available)	0 - 9999	1	-		Read Only	-	-

Register Address	Register Name	Data Range	Data Incr.	Data Default	R/W	Remark	Setpoint Inc.	Setpoint Default
1113	Time Stamp, Fault #2	EST 00.00-23.59	00.01	00.00		Read Only	00.01	00.00
1114	Date Stamp, Fault #2	01.01 – 12.31	00.01	01.01		Read Only	00.01	01.01
1115	Fault History #3, Oldest Fault	0, 31 – 50	1	0		Read Only	1	0
1116	Alarm / Trip Level (if available)	0 - 9999	1	-		Read Only	-	-
1117	Time Stamp, Fault #3	EST 00.00-23.59	00.01	00.00		Read Only	00.01	00.00
1118	Date Stamp, Fault #3	01.01 – 12.31	00.01	01.01		Read Only	00.01	01.01
1119	Present Event Record Number	0-447 0: Null Rec; Other: Rec.				Read Only	1	1
1120	Select Event Record Number [to navigate the record]	1-447					-	-
1121	Fault Code	0, 1 – 50	1	0		Read Only	1	0
1122	Alarm / Trip Level (if available)	0 - 9999	1			Read Only	-	-
1123	Time Stamp of Selected Event Record	00.00-23.59 (hh.mm) [hh = 00-23; mm = 00-59]				Read Only		
1124	Date Stamp of Selected Event Record	01.01 – 12.31 (MM.DD) [MM = 01-12; DD = 01-31]				Read Only		

4.5 Monitor Registers

Register Address	Register Name	Data Type			R/W		Actual Data Increment
2001	Hottest Stator ID	INT16	-	-	R/O	Sub-set of INT16	-
2002	Hottest Stator Temperature	INT16	-	-	R/O		-
2003	Hottest Non-Stator ID	INT16	-	-	R/O		-
2004	Hottest Non-Stator ID Temperature	INT16	-	-	R/O		-
2005	Stator 1 Temperature	INT16	-	-	R/O		-
2006	Stator 2 Temperature	INT16	-	-	R/O		-
2007	Stator 3 Temperature	INT16	-	-	R/O		-
2008	Stator 4 Temperature	INT16	-	-	R/O		-
2009	Stator 5 Temperature	INT16	-	-	R/O		-
2010	Stator 6 Temperature	INT16	-	-	R/O		-
2011	Front Bearing Temperature	INT16	-	-	R/O		-
2012	Rear Bearing Temperature	INT16	-	-	R/O		-
2013	Bearing Box Temperature	INT16	-	-	R/O		-
2014	Ambient Temperature	INT16	-	-	R/O		-
2015	RTD11 Temperature	INT16	-	-	R/O		-
2016	RTD12 Temperature	INT16	-	-	R/O		-
2017	Highest Temperature of RTD 1	INT16	-	-	R/O		-
2018	Highest Temperature of RTD 2	INT16	-	-	R/O		-
2019	Highest Temperature of RTD 3	INT16	-	-	R/O		-
2020	Highest Temperature of RTD 4	INT16	-	-	R/O		-
2021	Highest Temperature of RTD 5	INT16	-	-	R/O		-
2022	Highest Temperature of RTD 6	INT16	-	-	R/O		-
2023	Highest Temperature of RTD 7	INT16	-	-	R/O		-
2024	Highest Temperature of RTD 8	INT16	-	-	R/O		-
2025	Highest Temperature of RTD 9	INT16	-	-	R/O		-
2026	Highest Temperature of RTD 10	INT16	-	-	R/O		-
2027	Highest Temperature of RTD 11	INT16	-	-	R/O		-
2028	Highest Temperature of RTD 12	INT16	-	-	R/O		-
2029	Analog Input 1	INT16	-	-	R/O		-
2030	Analog Input 2	INT16	-	-	R/O		-
2031	Unit Temperature	INT16	-	-	R/O		-
2032	Differential Current Phase A	INT16	-	-	R/O		-
2033	Differential Current Phase B	INT16	-	-	R/O		-
2034	Differential Current Phase C	INT16	-	-	R/O		-
2035	Fault Class #	0-50	-	-	R/O		-
2036	Fault Code	0-50	-	-	R/O		-
2037	Relay Status	0-7	-	-	R/O		-

APPENDIX A: Technical Specifications

Control Voltage:	110 - 240Vac Nominal 50/60Hz
Inputs:	12 RTD inputs (Pt100, Ni100, Ni120, Cu10) 3 CT inputs for differential CT's 2 isolated 4-20mA inputs <input type="checkbox"/> 3 isolated Digital Inputs*
Outputs:	3 programmable form C Relays with 5A contact rating pilot duty One isolated 4-20mA output <input type="checkbox"/>
Keypad:	Two 4-digit displays, one for the RTD name (St1, St2, Fb, rb...) and one for the temperature. 1 green 'OK' LED, 1 yellow 'ALARM' LED, 1 red 'TRIP' LED and 3 Relay LED's. 7 pushbuttons: 4 arrows, 1 'Function', 1 'Enter' and a 'Reset' button
Differential CT's:	Primary 5 - 2000A Secondary 1A or 5A Alarm and Trip Levels OFF, 5% to 90 % of CT value Important: The differential CT feature is NOT designed to act as a UL Ground Fault or Over Current protection.
Resolution/Accuracy:	Analog Inputs better than 1% Analog Outputs better than 0.5%
Communication Port:	2 Wire RS485*
Protocol:	MODBUS RTU
I/O Terminals:	Removable terminal blocks
Operating Temperature:	32°F – 122°F / 0°C to 50°C
Storage Temperature:	-4°F – 176°F / -20°C to 80°C
Humidity:	10% to 90% (non-condensing)

* RS485 and Digital Inputs share a common ground point

All analog I/O share a common ground point.

Warranty information

1 Year Warranty: Phasetronics Inc., dba Motortronics, (hereinafter “Company”) warrants the **TE-RTD12 Series** products to be free from defects in material and/or workmanship for a period of one (1) year from the date of sale, or a maximum of 18 months from the date of manufacture (if no sales records are available) as indicated by the unit’s date code. The Company reserves the right to repair or replace any malfunctioning units or sub-assemblies under warranty at the Company’ sole option. Warranty repairs may be performed at the Company’s facility, in the field by a factory-authorized technician, or by the customer only with prior approval and at the specific direction of the Company’s Technical Services personnel. During the 1 year period, malfunctions of the control boards will be dealt with by replacement of the Modular Control Assembly (MCA), which contains the User Interface Panel, Digital Control Unit, Bypass control (if any) and Communications Interface. The MCA is designed to be replaced quickly without the need for tools (plug-in), and as such will constitute the majority of warranty replacements.

Warranty Service Procedure:

In the event that warranty service becomes necessary, contact the distributor where the starter was purchased, or Motortronics Technical Services department directly at (727) 573-1819. Be prepared to provide the complete Model number, Serial Number, date and place of purchase. It is also helpful to know the date of initial commissioning. When Technical Services has determined the nature of the problem and that sending replacement parts or assemblies can repair it, they will require a purchase order for replacement parts and issue a Return Material Authorization (RMA) for the defective parts or assemblies. If any components or assemblies are received at the factory without the proper RMA documentation, the shipment(s) will be refused.

When the replacement parts are received and evaluated at the factory, any warranty determination will result in an offsetting credit being issued for the replacement parts already sent out. If the unit is not needed for immediate operation, an alternative is to have the Technical Services representative provide an RMA for the components, and they will be evaluated and repaired at the factory, and returned. In either circumstance, freight/shipping costs are the responsibility of the purchaser.

Responsibility:

Company is not responsible for the misuse or misapplication of its products, intentional or otherwise. Improper application, installation, failure to provide safety devices or protective measures, or operation above its ratings, and failure to properly maintain or service products are all beyond the control and responsibility of the Company. Under no circumstances shall the Company be liable for loss of profits, indirect, incidental, special, consequential or other similar damages arising out of the misuse, misapplication or failure to maintain the Company’s products.

For the latest product information
visit us at www.motortronics.com